

**MINISTRY OF EDUCATION AND SCIENCE OF UKRAINE
STATE HIGHER EDUCATIONAL ESTABLISHMENT
UZHHOROD NATIONAL UNIVERSITY
FACULTY OF FOREIGN PHILOLOGY
ENGLISH LANGUAGE DEPARTMENT**

Myholynets O.I.

*Fundamentals of the Theory of
Speech Communication*

Uzhhorod 2021

УДК 811. 111'271–056.87(075.8)

ББК Ш143.21–72_я73–2

Ш₇₈

Миголинець О.І. Основи теорії мовленнєвої комунікації: навчально-методичне видання. – Ужгород: Ліра, 2021 . – 112 с. (видання друге, виправлене та доповнене).

Пропонований посібник задуманий передусім для студентів 4 курсу англійського відділення факультету іноземної філології денної форми навчання й ставить своєю метою ознайомлення студентів з основами теорії мовленнєвої комунікації. Навчальне видання представлено у формі 12 лекцій (з планом до кожної з них), в яких подано огляд основних питань, що стосуються теорії мовленнєвої комунікації, а саме: зародження та становлення останньої; визначення комунікації, її форми та типи. Особливої уваги заслуговує розгляд основних моделей та функцій комунікації. У полі зору знаходиться також цілий ряд питань, що торкаються компонентів комунікації, пов'язаних з комунікативним кодом (розглядається дискурс та дискурсивний аналіз, а також текст як одиниця комунікації) та ситуацією спілкування. Кожна лекція закінчується переліком питань та завдань для самоконтролю. У пригоді студентам стане також список рекомендованої літератури.

Навчально-методичне видання може бути використано як на практичних заняттях, так і при виконанні курсових, бакалаврських, магістерських та інших видів студентських робіт.

Contents

<i>Foreword</i>	4
<i>Lecture 1 Communication theory. Inaugural lecture</i>	6
<i>Lecture 2 Communication. Key concepts</i>	12
<i>Lecture 3 Models of communication</i>	21
<i>Lecture 4 Types of communication</i>	29
<i>Lecture 5 Functions of communication</i>	40
<i>Lecture 6 Forms of communication</i>	48
<i>Lecture 7 General characteristics of the components of communicative/speech act</i>	52
<i>Lecture 8 Components of communicative act connected with the language code. Discourse and discourse analysis</i>	61
<i>Lecture 9 Text as a result and unit of communication</i>	71
<i>Lecture 10 Components of communication connected with communicative situation</i>	77
<i>Lecture 11 Speech act in the structure of message (communication)</i>	86
<i>Lecture 12 Gender communication</i>	92

Foreword

This text introduces the fundamentals of speech communication to students who have little or no background in communication theory. Its three overriding goals are to help the students understand the pervasiveness of communication in their lives, to demystify the theoretical process, and to help students become more systematic and critical in their thinking about theory.

We have tried to describe various aspects in speech communication. The book is structured into 12 lectures. The introductory foundations lectures are dedicated to elucidating the origin of communication theory, its connection with other disciplines, and analysis of such key concepts as: communication, communication process, the components and characteristics of communication etc. Much attention has been paid to the analysis of communication forms and types as well as the models of communication. We have also concentrated on the components of communicative (speech) act with a special emphasis on discourse (discourse analysis) and text.

Each lecture is followed by self-check test, which aims at helping the students to master their knowledge in different aspects of communication theory. Recommended readings at the end of every lecture point to the literature sources where readers can find further information to enrich their study of communication. In preparing this edition the author has tried to take into consideration the latest achievements in different branches of linguistics.

At the end of the course the students are expected to brush up their knowledge in the field of communication theory and master a number of concepts, which might be helpful both in their studies and life.

Lecture 1

Communication theory. Inaugural lecture

Plan

1. *The academic study of communication theory.*
2. *The development of communication studies in the USA*
3. *Theoretical conception of Robert Craig*
4. *Communication theory framework.*
5. *The connection of communication theory with other disciplines.*

1. The academic study of communication

Communication theory as a named and a unified discipline has a history that goes back to the Socratic dialogues, in many ways making it the first and most contestatory of all early sciences and philosophies. Aristotle first addressed the problem of communication and attempted to work out a theory of it in *The Rhetoric*. He was primarily focused on the art of persuasion. **Communication theory** is a field of study that analyzes the technical process of information transmission and the human process of human communication. According to communication theorist Robert T. Craig in his 1999's essay 'Communication Theory as a Field', "*despite the ancient roots and growing profusion of theories about communication,*" there is not a field of study that can be identified as 'communication theory'. Communication theory is an academic field that deals with *the processes of communication*, commonly defined *as the sharing of symbols over distances in space and time*.

Communication studies encompass a wide range of topics and contexts ranging from face-to-face conversation to speeches to mass media outlets such as television broadcasting.

Communication studies often overlaps with academic programs in journalism, film and cinema, radio and television, advertising and public relations and performance studies.

The origins of communication theory is linked to the development of information theory. Limited information-theoretic ideas had been developed at Bell Labs, all implicitly assuming events of equal probability.

Harry Nyquist's 1924 paper, *Certain Factors Affecting Telegraph Speed*, contains a theoretical section quantifying "intelligence" and the "line speed" at which it can be transmitted by a communication system.

Ralph Hartley's 1928 paper, *Transmission of Information*, uses the word *information* as a measurable quantity, reflecting the receiver's ability to distinguish one sequence of symbols from any other. The natural unit of information was therefore the decimal digit, much later renamed the hartley in his honour as a unit or scale or measure of information.

Alan Turing in 1940 used similar ideas as part of the statistical analysis of the breaking of the German second world war Enigma ciphers.

The main landmark event that opened the way to the development of communication theory was the publication of an article by Claude E. Shannon in the Bell System Technical Journal in July and October 1948 under the title 'A Mathematical Theory of Communication. Shannon focused on the problem of how best to encode the information that a sender wants to transmit.

Communication theory has one universal law posited by S.F.Scudder. The universal communication law states that all living entities, beings and creatures communicate. All of the living communicates through movements, sounds, reactions, physical changes, gestures, languages, breath, etc. Communication is a means of survival – the cry of a child (communicates that it is hungry, hurt, cold, etc.), the browning of a leaf (communicates that it is dehydrated, thirsty and dying); the cry of an animal (communicates that it is injured, hungry, angry, etc.). Everything living communicates in its quest for survival.

2. *The development of communication studies in the USA*

Though the study of communication reaches back to antiquity and beyond, early twentieth-century work by *Charles Horton Cooley, Walter Lippmann, and John Dewey* have been of particular importance for the academic discipline as it stands today. In his 1909 *Social Organization: a Study of the Larger Mind*, Cooley defines communication as "the mechanism through which human relations exist and develop—all the symbols of the mind, together with the means of conveying them through space and preserving them in time." This view gave processes of communication a central and constitutive place in the study of social relations. *Public Opinion*, published in 1922 by Walter Lippmann, couples this view with a fear that the rise of new technologies in mass communication allowed for the 'manufacture of consent,' and generated dissonance between what he called 'the world outside and the pictures in our heads,' referring to the rift between the idealized concept of democracy and its reality. John Dewey's 1927 *The Public and its Problems* drew on the same view of communications, but instead took a more optimistic reform agenda, arguing famously that "communication can alone create a great community," as well as "of all affairs, communication is the most wonderful." Cooley, Lippmann, and Dewey capture themes like the central importance of communication in social life, the impact of changing technology upon culture, and questions regarding the relationship between communication, democracy, and community. These concepts continue to drive scholars today. Many of these concerns are also central to the work of writers such as *Gabriel Tarde and Theodor W. Adorno*, who have also made significant contributions to the field. In 1925, Herbert A. Wichelns published the essay "The Literary Criticism of Oratory" in the book *Studies in Rhetoric and Public Speaking in Honor of James Albert Winan*. Wichelns's essay attempted to "put rhetorical studies on par with literary studies as an area of academic interest and research." Wichelns wrote that oratory should be taken as seriously as literature, and therefore, it should be subject to criticism and analysis.

The institutionalization of communication studies in U.S. higher education and research has often been traced to Columbia University, the University of Chicago, and the University of Illinois, where early pioneers such as Paul F. Lazarsfeld, Harold Lasswell, and Wilbur Schramm worked. The Bureau of Applied Social Research was established in 1944 at Columbia University by Paul F. Lazarsfeld. It was a continuation of the Rockefeller Foundation-funded Radio Project that he had led at various institutions (University of Newark, Princeton) from 1937, which had been at Columbia as the Office of Radio Research since 1939. In its various incarnations, the Radio Project had involved Lazarsfeld himself, and people like Adorno, Hadley Cantril, Herta Herzog, Gordon Allport, and Frank Stanton (who went on to be president of CBS). Lazarsfeld and the Bureau mobilized substantial sums for research, and produced, with various co-authors, a series of books and edited volumes that helped define the discipline, such as *Personal Influence* (1955) which remains a classic in what is called the 'media effects'-tradition.

From the 1940s and onwards, the University of Chicago was home to several committees and commissions on communications, as well as programs that educated communication scholars. In contrast to what took place at Columbia, these programs explicitly claimed the name 'communications' for themselves. The Committee on Communication and Public Opinion, also funded by the Rockefeller Foundation, was staffed with, in addition to Lasswell, people such as Douglas Waples, Samuel A. Stouffer, Louis Wirth, and Herbert Blumer, all of whom held positions elsewhere at the university. They formed a committee that essentially served as a scholarly and educational extension of the federal government's increasing interest in communications during times of war, particularly the Office of War Information. Chicago later provided an institutional home for The Hutchins Commission on the Freedom of the Press and the Committee on Communication (1947–1960).

The Institute for Communications Research was founded at the University of Illinois at Urbana-Champaign in 1947 by Wilbur Schramm, who was a key figure in the post-war institutionalization of communication studies in the U.S. Like the various Chicago committees, the Illinois program claimed the name 'communications' and granted graduate degrees in the subject. Schramm, who, in contrast to the more social science-inspired figures at Columbia and Chicago, had a background in English literature, developed communication studies partly by merging existing programs in speech communication, rhetoric, and, especially, journalism under the aegis of communication. He also edited a textbook *The Process and Effects of Mass Communication* (1954) that helped define the field, partly by claiming Lazarsfeld, Lasswell, Carl Hovland, and Kurt Lewin as its founding fathers. He also wrote several other manifestos for the discipline, including *The Science of Human Communication* 1963. Schramm established three important communication institutes: the Institute of Communications Research (University of Illinois), the Institute for Communication Research (Stanford University), and the East-West Communication Institute (Honolulu).

Universities combined scholars of speech and mass media together under the term communication, which turned out to be a difficult process. While east coast universities did not see human communication as an important area for research, the field grew in the midwest. The first college of communication was founded at Michigan State University in 1958, led by scholars from Schramm's original ICR and dedicated to studying communication scientifically. MSU was soon followed by important departments of communication at the University of Texas-Austin, Stanford University, University of Iowa, and the University of Illinois. Walter Annenberg endowed three Schools for Communication at the University of Pennsylvania, The University of Southern California, and Northwestern University.

Two developments in the 1940s shifted the paradigm of communication studies in the 1950s and thereafter toward a more quantitative orientation. One was cybernetics, as formulated by Norbert Wiener in his *Cybernetics: Or the Control and Communication in the Animal and the Machine*. The other was information theory, as recast in quantitative terms by Claude E. Shannon and Warren Weaver in their *Mathematical Theory of Communication*. These works were widely appropriated to, and offered for some the prospect of, a general theory of society.

In the 1960s, Gould and his colleagues experienced increasing demand for doctoral-level studies in technical and business communication. The 1960s and 1970s saw the development of cultivation theory, pioneered by George Gerbner at the Annenberg School for Communication at the University of Pennsylvania. This approach shifted emphasis from the short-term effects that had been the central interest of many earlier media studies, and instead tried to track the effects of exposure across time.

In the early 1960s Communication Studies began to move towards a more independent field, and move out of the departments of sociology, political science, psychology, and English. The changes in the department are considered a result of the historical events taking place at the time. "Despite the different interpretations given to the changes around the time of World War II, mostly shaped by increasing technological innovations in the ways people communicate, communication became a relevant and recurrent issue in human and social science, opening the doors to the centrality of communication in social theories in the 1960s and 1970s." As a result of many of these sociological changes taking place in society, communication and mass media acquired the role of explaining these changes to the public. In response to the Civil Rights Movement, Vietnam War, and other dramatic cultural shifts, critics using Marxist and feminist theory to study dominant cultures became prominent in scholarly conversations. Cultural Studies related to mass media and critics asked why a number of big organizations had such an influence on society.

The Journal of Communication referred to the 1970s as a "time of ferment, particularly in the speech field. As social scientists pushed for recognition of 'communication' as the dominant term, rhetorical and performance scholars reconsidered and redefined their theories and methodologies." Speech Criticism combined with other sectors such as journalism and broadcasting to form

Communication Studies. In addition to the subgroups of the field making changes, national associations frequently changed their formal names to adapt to the growing field of communication. For example, in 1970 the Speech Association of America became the Speech Communication Association. Radio and television continued to develop throughout the 1970s and this boom in diversity “forced scholars to adopt a more convergent model of communication.” There was no longer only one source for each message and there was almost always more than one path from sender to receiver.

In 1980 the US Department of Education classified “communication” as a practical discipline, which was associated primarily with learning journalism and media production. The same classification system deemed speech and rhetorical studies a subcategory of English. By the 1980s many colleges and universities across the country decided to rename departments to include the word “communication” in the department title. Other schools began titling their departments **Mass Communication**, or created independent communication departments. “Often these new schools merge the professional fields of print, broadcast, public relations, advertising, information science, and speech with growing research programs more broadly defined communication research.” From this point in time communication studies began to gain recognition in schools worldwide.

3. *Theoretical conception of Robert Craig*

***Communication Theory as a Field* article by Robert Craig.** Communication theory textbooks had little to no agreement on how to present the field or what theories to include in their textbooks. This article has since become the foundational framework for different textbooks to introduce the field of communication.

In this article Craig "proposes a vision for communication theory that takes a huge step toward unifying this rather disparate field and addressing its complexities." To move toward this unifying vision Craig focused on **communication theory as a practical discipline** and shows how "various traditions of communication theory can be engaged in dialogue on the practice of communication." In this deliberative process theorists would engage in dialog about the "practical implications of communication theories." In the end Craig proposes seven different traditions of Communication Theory and outlines how each one of them would engage the others in dialogue.

1. **Rhetorical: views communication as the practical art of discourse.**

Rhetoric is the art of discourse, wherein a writer or speaker strives to inform, persuade or motivate particular audiences in specific situations. As a subject of formal study and a productive civic practice, rhetoric has played a central role in the European tradition. Its best known definition comes from Aristotle, who considers it a counterpart of both logic and politics, and calls it "the faculty of observing in any given case the available means of persuasion."

2. **Semiotic: views communication as the mediation by signs.**

Semiotics (also called **semiotic studies**) is the study of meaning-making, the study of sign process (semiosis) and meaningful communication. It is not to be confused with the Saussurean tradition called semiology which is a subset of semiotics. This includes the study of signs and sign processes, indication, designation, likeness, analogy, allegory, metonymy, metaphor, symbolism, signification, and communication. The semiotic tradition explores the study of signs and symbols as a significant part of communications. As different from linguistics, however, semiotics also studies non-linguistic sign systems. Semiotics is frequently seen as having important anthropological dimensions; for example, the Italian semiotician and novelist Umberto Eco proposed that every cultural phenomenon may be studied as communication. Some semioticians focus on the logical dimensions of the science, however.

3. Phenomenological: communication is the experience of dialogue with others.

Phenomenology (from Greek *phainómenon* "that which appears" and *lógos* "study") is the philosophical study of the structures of experience and consciousness. As a philosophical movement it was founded in the early years of the 20th century by Edmund Husserl and was later expanded upon by a circle of his followers at the universities of Göttingen and Munich in Germany. It then spread to France, the United States, and elsewhere, often in contexts far removed from Husserl's early work. Phenomenology should not be considered as a unitary movement; rather, different authors share a common family resemblance but also with many significant differences. Accordingly: A unique and final definition of phenomenology is dangerous and perhaps even paradoxical as it lacks a thematic focus. In fact, it is not a doctrine, nor a philosophical school, but rather a style of thought, a method, an open and ever-renewed experience having different results.

4. Cybernetic: communication is the flow of information.

Cybernetics is a transdisciplinary approach for exploring different systems—their structures, constraints, and possibilities. Norbert Wiener defined cybernetics in 1948 as "the scientific study of control and communication in the animal and the machine." In the 21st century, the term is often used in a rather loose way to imply "control of any system using technology." In other words, it is the scientific study of how humans, animals and machines control and communicate with each other.

5. Socio-psychological: communication is the interaction of individuals.

In sociology, **social psychology**, also known as **sociological social psychology** or **microsociology**, is an area of sociology that focuses on social actions and on interrelations of personality, values, and mind with social structure and culture. Some of the major topics in this field are social status, structural power, sociocultural change, social inequality and prejudice, leadership and intra-group behavior, social exchange, group conflict, impression formation and management, conversation

structures, socialization, social constructionism, social norms and deviance, identity and roles, and emotional labor. The primary methods of data collection are sample surveys, field observations, vignette studies, field experiments, and controlled experiments.

6. Socio-cultural: communication is the production and reproduction of the social evolution.

Sociocultural evolution, sociocultural evolutionism or cultural evolution are theories of cultural and social evolution that describe how cultures and societies change over time. Whereas **sociocultural development** traces processes that tend to increase the complexity of a society or culture, sociocultural evolution also considers process that can lead to decreases in complexity (degeneration) or that can produce variation or proliferation without any seemingly significant changes in complexity. Sociocultural evolution is "the process by which structural reorganization is affected through time, eventually producing a form or structure which is qualitatively different from the ancestral form".

7. Critical: communication is the process in which all assumptions can be challenged.

Critical Theory is a school of thought that stresses the reflective assessment and critique of society and culture by applying knowledge from the social sciences and the humanities. As a term, *Critical Theory* has two meanings with different origins and histories: the first originated in sociology and the second originated in literary criticism, whereby it is used and applied as an umbrella term that can describe a theory founded upon critique; thus, the theorist Max Horkheimer described a theory as critical insofar as it seeks "to liberate human beings from the circumstances that enslave them".

4. *Communication theory framework*

It is helpful to examine communication and communication theory through one of the following viewpoints:

- *Mechanistic*: this view considers communication to be a perfect transaction of a message from the sender to the receiver.
- *Psychological*: this view considers communication as the act of sending a message to a receiver, and the feelings and thoughts of the receiver upon interpreting the message.
- *Social*: this view considers communication to be the product of the interactants sharing and creating meaning.
- *Systemic*: this view considers communication to be the new messages created via "through-put", or what happens as the message is being interpreted and re-interpreted as it travels through people.

Communication theory can also be studied and organized according to the *ontological, epistemological, and axiological* framework. Let us analyze these concepts.

Ontology poses the question of what the theorist is examining. One must consider the very nature of reality. The answer usually falls in one of three realms depending on whether the theorist sees the phenomena through the lens of a realist, nominalist, or social constructionist. Realist perspective considers the world objectively, believing that there is a world outside of our own experience and cognitions. Nominalists see the world subjectively, claiming that everything outside of one's cognitions is simply names and labels. Social constructionists straddle the fence between objective and subjective reality, claiming that reality is what we create together.

Epistemology is the examination of how the theorist studies the chosen phenomena. In studying epistemology, objective knowledge is said to be the result of a systematic look at the causal relationships of phenomena. This knowledge is usually attained through the usage of the scientific method. Scholars often think that empirical evidence (practical data) collected in an objective manner is most likely to reflect truth in the findings. Theories of this type are usually created to predict a phenomenon. Subjective theory holds that understanding is based on situated knowledge, typically found using interpretative methodology such as ethnography and interviews. Subjective theories are typically developed to explain or understand phenomena in the social world.

Axiology is concerned with what values drive a theorist to develop a theory. Theorists must be mindful of potential biases so that they will not influence or skew their findings.

5. The connection of communication theory with other disciplines

Information theory

In the early 1940's a mathematical theory, for dealing with the more fundamental aspects of communication systems, was developed. The distinguishing characteristics of this theory are, first, a great emphasis on probability theory and, second, a primary concern with the encoder and decoder, both in terms of their functional roles and in terms of the existence (or nonexistence) of encoders and decoders that achieve a given level of performance. In the past 20 years, information theory has been made more precise, has been extended, and brought to the point where it is being applied in practical communication systems. As in any mathematical theory, it deals only with mathematical models and not with physical sources and physical channels.

Communicology

Communicology is the study of the art and science of communication. It studies the structure and dynamics of communication and is the result of decades of

development within a range of subjects and fields: educational science, counseling, health, negotiation, cooperation, management, etc. and research within those fields. The material is built upon a research approach best characterized as comparative studies of practitioners, methods, theories, models within and between various subjects and fields. Similarities and differences in vast amounts of information, knowledge, competence, concepts have been studied for identifying, elucidating and making accessible "masterkeys" – the active ingredients in communication and change. It is specifically related to the advertising, marketing and media industry. Someone who studies communicology is called a communicologist.

Pragmatic linguistics

Pragmatics – a subfield of linguistics developed in the late 1970s – studies how people comprehend and produce a communicative act or speech act in a concrete speech situation which is usually a conversation (hence conversation analysis). It distinguishes two intents or meanings in each utterance or communicative act of verbal communication. One is the *informative intent* or the sentence meaning, and the other one – the *communicative intent* or speaker meaning. The ability to comprehend and produce a communicative act is referred to as pragmatic competence, which often includes one's knowledge about the social distance, social status between the speakers involved, the cultural knowledge such as politeness, and the linguistic knowledge explicit and implicit. Some of the aspects of language studied in pragmatics include:

–*Deictic*: meaning 'pointing to' something. In verbal communication however, deixis in its narrow sense refers to the contextual meaning of pronouns, and in its broad sense, what the speaker means by a particular utterance in a given speech context.

–*Presupposition*: referring to the logical meaning of a sentence or meanings logically associated with or entailed by a sentence.

–*Performative*: implying that by each utterance a speaker not only says something but also does certain things: giving information, stating a fact or hinting an attitude. The study of performatives led to the hypothesis of *speech act theory* that holds that a speech event embodies three acts: a locutionary act, an illocutionary act and a perlocutionary act.

–*Implicature*: referring to an indirect or implicit meaning of an utterance derived from context that is not present from its conventional use.

The pragmatic principles people abide by in one language are often different in another. Thus, there has been a growing interest in how people in different languages observe a certain pragmatic principle. Cross-linguistic and cross-cultural studies reported what is considered polite in one language is sometimes not polite in another. Contrastive pragmatics, however, is not confined to the study of certain

pragmatic principles. Cultural breakdowns, pragmatic failure, among other things, are also components of cross-cultural pragmatics.

Another focus of research in pragmatics is learner language or interlanguage. This interest eventually evolved into interlanguage pragmatics, a branch of pragmatics which specifically discusses how non-native speakers comprehend and produce a speech act in a target language and how their pragmatic competence develops over time.

Functional linguistics

Those who call themselves *functional linguists* differ on many aspects of linguistic theory, but the one central principle they all share is the answer to the question: “What constitutes a satisfactory explanation for the observable facts about language?” Functional explanations are based on communicative function. Languages around the world are in some ways very similar and in other ways radically different because they have been shaped by differing social, and historical processes, but for the one universal purpose of communication based on human cognition. This is in contrast to a formalist explanation that seeks to explain observable (surface) facts about language in terms of a deeper (underlying) level of language.

The core principles that characterize functional linguistics:

- All areas of linguistics (phonetics, phonology, morphology, syntax, semantics, pragmatics, discourse) are interrelated. There are no clear-cut boundaries between them. Language similarities are based on similar human needs for communication and on general cognitive functions of the human brain.
- Diachronic processes (language evolution) must be taken into account for a complete understanding of a language at any given time. This is in contrast to formalist approaches that attempt purely synchronic (language use at a given point in history) explanations of language.

Psycholinguistics

Psycholinguistics is the the study of psychological aspects of language. Experiments investigating such topics as short-term and long-term memory, perceptual strategies, and speech perception based on linguistic models are part of this discipline. Most work in psycholinguistics has been done on the learning of language by children. Language is extremely complex, yet children learn it quickly and with ease; thus, the study of child language is important for psychologists interested in cognition and learning and for linguists concerned with the insights it can give about the structure of language. In the 1960s and early '70s much research in child language used the transformational-generative model proposed by the American linguist Noam Chomsky; the goal of that research has been to discover how children come to know the grammatical processes that underlie the speech they hear. The transformational model has also been adapted for another field of

psycholinguistics, the processing and comprehension of speech; early experiments in this area suggested, for example, that passive sentences took longer to process than their active counterparts because an extra grammatical rule was necessary to produce the passive sentence. Many of the results of this work were controversial and inconclusive, and psycholinguistics has been turning increasingly to other functionally related and socially oriented models of language structure.

Self-check test

1. Describe the origin of communication theory.
2. Characterize mechanistic, psychological, social, and systemic views on communication.
3. Describe ontology, epistemology, sociology.
4. Point to the connection of communication theory with other disciplines.

Recommened Readings

1. DeLancey S. On Functionalism / Functional Syntax Lectures / Online: <http://darkwing.uoregon.edu/~delancey/sb/fs.html>, 2001.
2. Dryer M.S. Functionalism and the Theory – Metalanguage Confusion / Phonology, Morphology, and the Empirical Imperative / Taipei: The Crane Publishing Company, 2006. P. 27-59.
3. Givón T. Syntax: An introduction. – Philadelphia: John Benjamins, 2018.– 500 p.
4. Griffin. E. A first look at communication theory. – New York: McGraw-Hill, 1997.– 214 p.
5. Harris R. The Linguistic Wars. – New York: Oxford University Press, 2005. – 238 p.
6. Haspelmath M. Does linguistic explanation presuppose linguistic description? Studies in Language, 2014. – 341 p.
7. Leech G. Principles of pragmatics. – London: Longman, 1989. – 250 p.
8. Miller K. Communication Theories: Perspectives, Processes, and Contexts. New York: McGraw-Hill, 2015. – 352 p.
9. Sperber D., Wilson D. Relevance: Communication and Cognition. – Basil Blackwell, 1986. –320 p.
10. Werner E. Toward a Theory of Communication and Cooperation for Multiagent Planning / Theoretical Aspects of Reasoning About Knowledge / Proceedings of the Second Conference. – London: Morgan Kaufman Publishers, 2020. – P. 129-143.

Lecture 2

Communication. Key concepts

Plan

1. *Defining communication.*
2. *Communication process.*
 - 2.a. *Barriers to communication.*
 - 2.b. *Active listening.*
3. *Components of communication.*
4. *Characteristics of communication.*

1. *Defining communication*

Communication has existed since the beginning of human beings, but it was not until the 20th century that people began to study the process. Humanistic and rhetorical viewpoints and theories dominated the discipline prior to the twentieth century, when more scientific methodologies and insights from psychology, sociology, linguistics and advertising began to influence communication thought and practice. As communication technologies developed, so did the serious study of communication. Communication studies focus on communication as central to the human experience, which involves understanding how people behave in creating, exchanging, and interpreting messages. When World War I ended, the interest in studying communication intensified. Before becoming simply communication theory, or communication studies, the discipline was formed from three other major studies: *psychology, sociology, and anthropology*. Psychology is the study of human behavior, sociology is the study of society and social process, and anthropology is the study of communication as a factor, which develops, maintains, and changes culture. Though communication theory remains a relatively young field of study, it is also closely connected with other disciplines such as philosophy. It is very difficult to expect a consensus understanding of communication across disciplines.

Communication is studied under many different names at different universities and in various countries, including "communication", "communication studies", "speech communication", "rhetorical studies", "communications science", "media studies", "communication arts", "mass communication", "media ecology", "communication and media science" and sometimes even "mediology".

Since the beginning of time, the need to communicate emerges from a set of universal questions: Who am I? Who needs to know? Why do they need to know? How do I want people to respond? It is often formed around the principles of respect, promises and the want for social improvement. People communicate to satisfy needs both in their work and non-work lives. People want to be heard, to be appreciated and to be wanted. They also want to accomplish tasks and achieve goals. Obviously, a major purpose of communication is to help people feel good about themselves and their friends, groups, and organizations. To satisfy this there must be a transmission of thoughts, ideas and feelings from one mind to another. The word *communication* is abstract and, like many other words, possesses multiple meanings.

Scholars have made many attempts to define its meaning. **The subject of communication has concerned them since the time of ancient Greece.** The word *communication* comes from the Latin *communis* which means "to impart, share," "to make common". When we communicate, we are trying to establish commonness with someone, that is, we are trying to share information, an idea or an attitude. Some scholars limit their definitions of communication rather narrowly, saying that communication is the process whereby one person tells another something through the written or spoken word. The idea of sharing the information is the principal one in most definitions. Some of the definitions of communication are very comprehensive, include several meanings, recognizing that animals and plants can communicate with each other as well as human beings. Some are narrow and include only human beings. C. Hovland, a well-known psychologist of a few years ago, said that communication is the process by which an individual (the communicator) transmits stimuli (usually verbal symbols) to modify the behavior of the other individuals. In 1928 the English literary critic and author I. Richards offered one of the first — and in some ways still the best — definitions of communication: "Communication takes place when one mind so acts upon its environment that another mind is influenced, and in that other mind an experience occurs which is like the experience in the first mind, and is caused in part by that experience". According to the encyclopedia Britannica communication is the exchange of information between individuals through a common system of verbal symbols.

Being seen as the processes of information transmission communication is governed by three levels of semiotic rules: *syntactic* (describe formal properties of signs and symbols), *pragmatic* (are concerned with the relations between signs/expressions and their users) and *semantic* (study the relationships between signs, symbols and what they represent).

2. Communication process

To communicate effectively we need to be familiar with the factors involved in the communication process. If we are aware of them, these factors will help us plan, analyze situations, solve problems, and in general do better our work no matter what our job might be. Communication is usually described along a few major dimensions:

1. Content (*what type of things are communicated*);
2. Source (*by whom*);
3. Form (*in which form*);
4. Channel (*through which medium*);
5. Destination/Receiver (*to whom*);
6. Purpose/Pragmatic aspect (*with what kind of results*).

In a simplistic model information or content (a message) is sent in some form (spoken language) from a /sender/encoder to a /receiver/decoder. (Fig. 1).

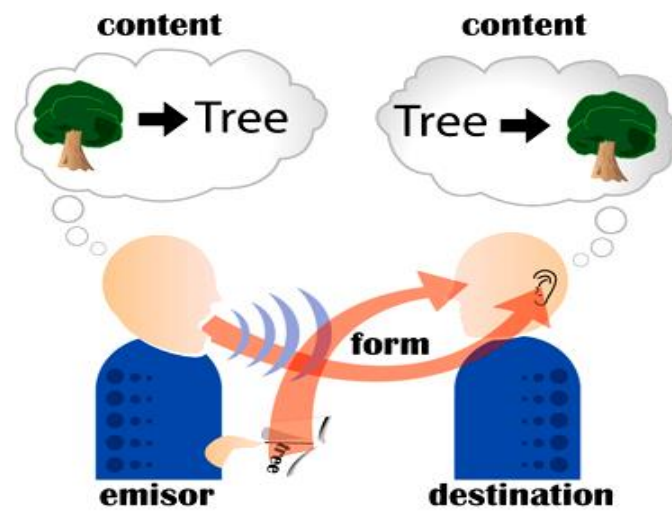

Fig.1 Communication process

In a slightly more complex form a sender and a receiver are linked reciprocally (Fig.2).

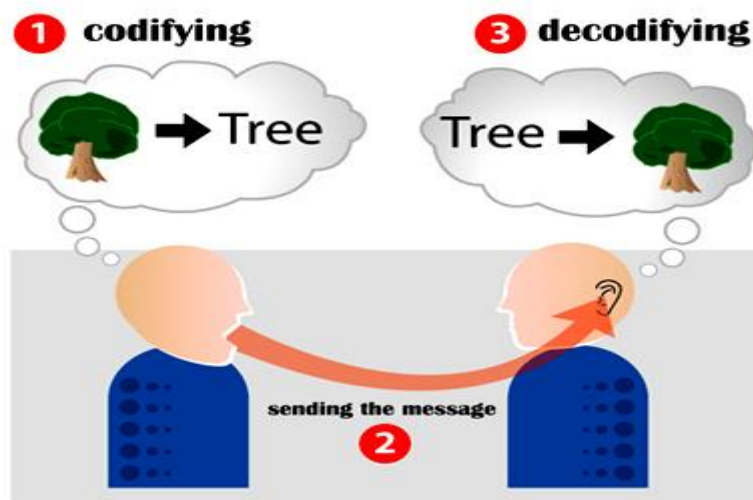

Fig.2 The process of information transmission

In the process of transmitting the message two processes will be received by the receiver: *content* and *context*. *Content* is the actual words or symbols of the message which is known as *language* – the spoken and written words combined into phrases that make grammatical and semantic sense. We all use and interpret the meanings of words differently, so even simple messages can be misunderstood. And many words have different meanings to confuse the issue even more. *Context* is the way the message is delivered and is known as *paralanguage* – it includes the tone of voice, the look in the sender's eyes, body language, hand gestures, and the state of emotions (anger, fear, uncertainty, confidence, etc.) that can be detected.

2.a. Barriers to communication

Anything that prevents understanding of the message is a barrier to communication. Many physical and psychological barriers exist:

- **Culture, background, bias.** We allow our past experiences to change the meaning of the message. Our culture, background, and bias can be good as they allow us to use our past experiences to understand something new, it is when they change the meaning of the message then they interfere with the communication process.
- **Noise.** Noise impedes clear communication. The sender and the receiver must both be able to concentrate on the messages being sent to each other.

Types of the noise:

Environmental Noise: Noise that physically disrupts communication, such as standing next to loud speakers at a party, or the noise from a construction site next to a classroom making it difficult to hear the professor.

Physiological-Impairment Noise: Physical maladies that prevent effective communication, such as actual deafness or blindness preventing messages from being received as they were intended.

Semantic Noise: Different interpretations of the meanings of certain words. For example, the word "weed" can be interpreted as an undesirable plant in your yard, or as a euphemism for marijuana.

Syntactical Noise: Mistakes in grammar can disrupt communication, such as abrupt changes in verb tense during a sentence.

Organizational Noise: Poorly structured communication can prevent the receiver from accurate interpretation. For example, unclear and badly stated directions can make the receiver even more lost.

Cultural Noise: Stereotypical assumptions can cause misunderstandings, such as unintentionally offending non-Christian persons by wishing them a "Merry Christmas."

Psychological Noise: Certain attitudes can also make communication difficult. For instance, great anger or sadness may cause someone to lose focus on the present moment. Disorders such as autism may also severely hamper effective communication.

- **Ourselves.** Focusing on ourselves, rather than the other person, can lead to confusion and conflict. The "Me Generation" is out when it comes to effective communication. Some of the factors that cause this are defensiveness (we feel

someone is attacking us), superiority (we feel we know more than the others), and ego (we feel we are the centre of the activity).

- **Perception.** If we feel the person is talking too fast, not fluently, does not articulate clearly, etc., we may dismiss this person. Our preconceived attitudes also affect our ability to listen. We listen uncritically to persons of high status and dismiss those of low status.
- **Message.** Distractions happen when we focus on the facts rather than the idea. Semantic distractions occur when a word is used differently than you prefer. For example, the word *chairman* instead of *chairperson*, may cause you to focus on the word and not on the message.
- **Environmental.** Bright lights, an attractive person, unusual sights, or any other stimulus provide a potential distraction.
- **Stress.** People do not see things the same way when under stress. What we see and believe at a given moment is influenced by our psychological frames of references – our beliefs, values, knowledge, experiences, and goals.

These barriers can be thought of as filters, that is, the message leaves the sender, goes through the above filters, and is then heard by the receiver. These filters muffle the message.

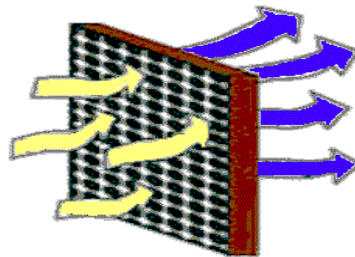

Fig.3 Barriers of communication

There are different ways how to overcome these filters/barriers of communication.

2.b. Active listening

The way to overcome filters is through active listening. Hearing and listening is not the same thing. Hearing is the act of perceiving the sounds. It is involuntary and simply refers to the reception of aural stimuli. Listening is a selective activity which involves the reception and the interpretation of aural stimuli. It involves decoding the sound into meaning. Listening is divided into two main categories: passive and active. Passive listening is little more than hearing. It occurs when the receiver or the message has little motivation to listen carefully, such as music, story telling, television, or being polite. People speak at 100 to 175 words per minute, but they can listen intelligently at 600 to 800 words per minute. Since only a part of our mind is paying attention, it is easy to go into *mind drift* – thinking about other things

while listening to someone. The cure for this is *active listening* – which involves listening with a purpose. It may be to gain information, obtain directions, understand others, solve problems, share interest, see how another person feels, show support, etc. It requires that the listener attends to the words and the feelings of the sender for understanding. It takes the same amount or more energy than speaking. It requires the receiver to hear the various messages, understand the meaning, and then verify the meaning by offering feedback.

The following are a few traits of active listeners:

- Spend more time listening than talking.
- Do not finish the sentences of others.
- Do not answer the questions with questions.
- Are aware of biases and control them.
- Never daydream or become preoccupied with their own thoughts when others talk.
- Let the other speaker talk. Do not dominate the conversation.
- Plan responses after the other person has finished speaking... NOT while they are speaking.
- Provide feedback, but do not interrupt incessantly.
- Keep the conversation on what the speaker says...NOT on what interests them.
- Take brief notes. This forces them to concentrate on what is being said.

3. Components of communication

All communication contacts have certain common elements that together help to define the communication process. The better you understand these elements, the easier it will be for you to develop your own communication abilities. Let us begin by examining the essentials of communication – those components present during every interpersonal, small group and public communication contact.

a) People

Obviously every human communication contact of any kind involves people. Interpersonal, small group and public communication encounters take place between and among all types of "*senders*" and "*receivers*". "Senders" and "receivers", respectively, are simply persons who give out and take in messages. Although it is easy to picture an interpersonal, small group or public communication experience as beginning with a sender and ending with a receiver, it is important to understand that during communication the sending role does not belong exclusively to one person and receiving role to another. Instead, the sending and receiving processes are constantly being reversed, and thus, when we communicate with one or more individuals, we simultaneously send and receive. If we were just senders, we would simply emit signals without ever stopping to consider whom, if anyone, we were affecting. If we were just the receivers, we would be no more than receptacles for signals from others, never having an opportunity to let anyone know how we were being affected. Fortunately,

this is not how effective communication works. The verbal and nonverbal messages that we send out are often determined by the verbal and nonverbal messages received from the others.

b) Messages

During every interpersonal, small-group or public communication contact we all send and receive both verbal and nonverbal messages. What you talk about, the words you use to express your thoughts and feelings, the sounds you make, the way you sit and gesture, your facial expressions and perhaps even your touches or your smell all communicate information. In effect, *the message is the content of a communicative act*. Some messages that we send are private (a kiss accompanied by the words "I love you "), and the others are public and directed at hundreds or thousands of people.

c) Channel

It is the system or method that we use to send or obtain information in the process of communication. We send and receive messages with and through all our senses; equally messages may be sent and received through both verbal and nonverbal models. Thus, in effect, we are multichannel communicators. We receive *sound messages* (noises from the street), *sight messages* (you see how someone looks), *taste messages* (you taste particular food), *smell messages* (you smell the eau-de-cologne of a friend), *touch messages* (you feel the roughness of a fabric). Effective communicators are adept channel switchers. They recognize that communication is a multichannel experience

d) Context

Communication always takes place in some context or setting. Two things are meant by context:

- 1) the situation, events or information that are related to something and that help you to understand it: political/social/historical etc. context, for instance, the political context of the election;
- 2) the words that come just before and after a word or a sentence and help you understand its meaning (the meaning of the word "mad" depends on its context).

Sometimes the context is so natural that we hardly notice it. At other times, however, the context makes such an impression on us that it exerts considerable control over our behaviour.

e) Feedback

The purpose of feedback is to change and alter messages so the intention of the original communicator is understood by the second communicator. Whenever we communicate with one or more persons, we also receive information in return. The verbal and nonverbal cues that we perceive in reaction to our communication function as feedback. Feedback tells us how we are coming across. A smile, a frown, a chuckle, a sarcastic remark, a muttered thought, or simply silence can cause us to change, modify, continue or end a transaction. Feedback that encourages us to continue behaving as we are, is *positive feedback*, and it enhances our behaviour in progress. In contrast, negative feedback serves to modify our behaviour and has a corrective function. Note that positive and negative should not be interpreted as

meaning "good" or "bad" but simply reflect the way these responses affect behaviour. Both positive and negative feedback can emanate from internal or external sources. *Internal feedback* is feedback you give yourself as you monitor your own behaviour or performance during a transaction. *External feedback* is the one from others, who are involved in the communication event. To be an effective communicator, you must be sensitive to both types of feedback. You must pay attention to your own reactions and the reactions of others.

C. Rogers listed five main categories of feedback. They are listed in the order in which they occur most frequently in daily conversations. Notice that we make judgments more often than we try to understand:

- *Evaluative*: Making a judgment about the worth, goodness, or appropriateness of the other person's statement.
- *Interpretive*: Paraphrasing – attempting to explain what the other person's statement means.
- *Supportive*: Attempting to assist or bolster the other communicator.
- *Probing*: Attempting to gain additional information, continue the discussion, or clarify a point.
- *Understanding*: Attempting to discover what the other communicator means by her statements.

f) Effect

A communication experience always has some effect on you and on the person or people with whom you are interacting. An effect can be *emotional, physical, cognitive* or any combination of all three. An interpersonal, small-group or public communication contact can elicit feelings of joy, anger or sadness (emotional); communication can cause you to fight, argue, become apathetic (physical); or it can lead to new insights, increased knowledge, the formation or reconsideration of opinions, silence or confusion (cognitive). The result of a communication encounter can also be any combination of all three effects just mentioned.

4.Characteristics of communication

Besides having specific ingredients or elements in common, all interpersonal, small-group and public communication experiences also share certain general characteristics:

a) Communication is a dynamic process. When we call communication a dynamic process, we mean that all its elements constantly interact and affect each other. Since all people are interconnected, whatever happens to one person determines in part what happens to others. Nothing about communication is static, everything is accumulative. We communicate as long as we are alive, and thus, every interaction that we engage in, is part of series of connected happenings. So, all our present communication experiences may be thought of as points of arrival from past encounters, and as points of departure for future ones.

b) Communication is unrepeatable and irreversible. Every human contact you experience is unique. It has never happened before, and it will never happen in

just that way again. An old proverb says "You can never step into the same river twice", because the experience changes both you and the river forever. Thus, communication is both unrepeatable and irreversible. We can neither take back something we have said nor evade the effects of something we have done. And although we may be greatly influenced by our past, we can never reclaim it.

Self-check test

1. What is communication?
2. Give C.Howland's definition of communication.
3. "Communication is governed by three levels of...". Continue the sentence.
4. Enumerate and describe the barriers to communication.
5. What are the features of active listeners?
6. What are the components of communication process? What is content, context?
7. Describe the components of communication.
8. What is feedback? What is positive feedback? What is negative feedback?
9. C.Rodger listed 5 categories of feedback, enumerate and describe them.
10. What are characteristics of communication?

Recommended Readings

1. Berko R. Communicating. – Boston, MA: Pearson Education, 2010. – P. 9-12.
2. Berlo D. The Process of Communication. – New York: Holt, Rinehart & Winston, 1960. – 289 p.
3. Haynes W. Shulman B.Communication Development: Foundations, Processes, and Clinical Applications: Williams & Wilkins; 2 Subedition, 1998. – 436 p.
4. Hovland C., Irving L. Communication and Persuasion: Psychological Studies of Opinion Change. – New Haven: Yale UP, 2018.– 338 p.
5. Littlejohn S., Foss K. Theories of Human Communication. – California: Wadsworth, 2002. – 221 p.
6. Richards I. The Meaning of Meaning: A Study of the Influence of Language upon Thought and of the Science of Symbolism. – London and New York, 1928. – 211 p.
7. Rogers C. On Personal Power: Inner Strength and Its Revolutionary Impact, 1977. – 189 p.
8. Schramm W. How Communication Works / The process and effects of communication. – Urbana, Illinois: University of Illinois Press, 2004. – P. 3-26.

Lecture 3

Models of communication

Plan

Models of communication.

- a. Aristotle's model.*
- b. Lasswell's model.*
- c. The Shannon and Weaver's model.*
- d. R.Jakobson model.*
- e. Schramm's model.*
- f. The Rileys' model.*
- g. Berlo's model.*
- h. Katz and Lazerfeld's model (two-step flow of communication).*

Models of communication

Communication models come in a variety of forms, ranging from catchy summations to diagrams and mathematical formulas. **According to McQuail and Windahl (1989): “Models simplify reality, select key elements, and indicate relationships”** (p. 36). The classical communication model, which is also the oldest one was proposed by the Greek philosopher-teacher Aristotle (384-322 B.C.).

a. Aristotle's model

Aristotle, writing 300 years before the birth of Christ, called the study of communication "rhetoric" and spoke of three elements within the process. He provided us with this insight:



Fig. 4 Aristotelian model of communication

Aristotle speaks of a communication process composed of a speaker, a message and a listener. He points out that ***the person at the end of the communication process holds the key to whether or not communication takes place***. It is necessary to recognize the importance of the audience at the end of the communication chain. We tend to be more concerned about ourselves as the communication source, about our message, and even the channel we are going to use. Too often, the listener, viewer, reader fails to get any consideration at all. Aristotle's words underscore the long interest in communication. They also indicate that the man has had a good grasp of what is involved in communication for a long while. So we might even wonder: If we know so much about the communication process, and if we've known it for so long, why do we still have problems with communication?

b. Lasswell's model

Harold Lasswell, a political scientist, developed a much quoted formulation of the main elements of communication: "Who says what in which channel to whom with what effect." This summation of the communication process has been widely quoted since the 1940s. The point in Lasswell's comment is that *there must be an "effect" if communication takes place*. If we have communicated, we've produced an effect. It's also interesting to note that Lasswell's version of the communication process mentions four parts - who, what, channel, whom. Three of the four parallel parts have been mentioned by Aristotle - speaker (who), subject (what), the person addressed (whom). Only channel has been added (Fig.5).



Fig. 5 Lasswell's model of communication

Most modern-day theorists discuss the four parts of the communication process, but use different terms to designate them.

c. The Shannon and Weaver's model

Communication models are divided into linear and non-linear. Among the early linear models we must single out the one proposed by Claude Shannon, an engineer for the Bell Telephone Company, and Warren Weaver, of the Rockefeller Foundation. This model is treated as the most influential of all early communication models.

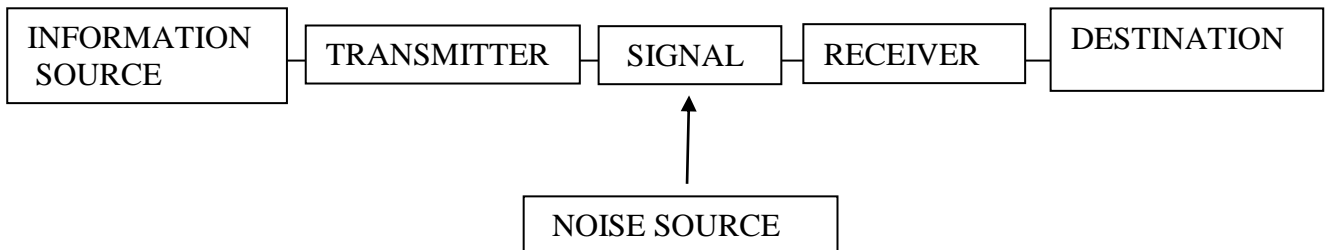

Fig. 6 Shannon and Weaver's model of communication

C. Shannon and W. Weaver attempted to do two things:

- Reduce the communication process to a set of mathematical formulas;
- Discuss the problems that could be handled with this model.

The Shannon-Weaver model proposed six elements of communication: source, encoder, message, channel, decoder, receiver. One may note that this diagram has essentially the same parts as the one formulated by Aristotle. It's true the parts have different names, and a fourth component – in this case the transmitter – is included. However, this model has another interesting additional

element. Shannon and Weaver were concerned with the noise in the communications process. Noise, Weaver said, "may be distortions of sound (in telephony, for example) or static (in radio), or distortions in shape or shading of picture (television), or errors in transmission (telegraph or facsimile), etc." The "noise" concept introduced by Shannon and Weaver can be also used to illustrate "*semantic noise*" that interferes with communication. Semantic noise is the problem connected with differences in meaning that people assign to words, to voice inflections in speech, to gestures and expressions and to other similar "noise" in writing. Semantic noise is a more serious problem or a barrier to developing effective communication than most realize. It is hard to detect that semantic noise has interfered with communication. Too often the person sending a message chooses to use words and phrases that have a certain meaning to him or her. However, they may have an altogether different meaning to individuals receiving the message. It is in the interest of good communication to work to hold semantic noise to the lowest level possible.

d. Jakobson's model

R. Jakobson, a Russian thinker who became one of the most influential linguists of the 20th century, proposed a communication model, consisting of 6 elements. These are: *context, message, sender, receiver, channel, code*. According to these components of communicative model six communication functions are distinguished.

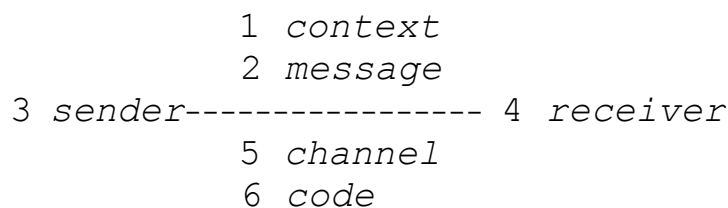

Fig.7 Jakobson's communication model

The first *referential* function corresponds to *contextual information*; the second *poetic* function depicts such a component of communication as a *message*; the third function, and namely, *emotive* points to the *sender* and is connected with *self-expression*. The *conative* communicative function realizes *vocative or imperative addressing* of receiver. The fifth communicative function *phatic* checks whether the *channel* is working. The last *metalingual* function of communication checks whether the code (that is the system of signals) is working.

e. Schramm's model

Wilbur L.Schramm was one of the forefathers in the development of a basic model of communication. His model is a derivation of the Shannon-Weaver transmission model of communication. This is the first example of the interactive models. Interactive models emphasize the process of encoding and decoding the

message. Wilbur Schramm considered this process as a two-way circular communication between the sender and receiver (Fig.8).

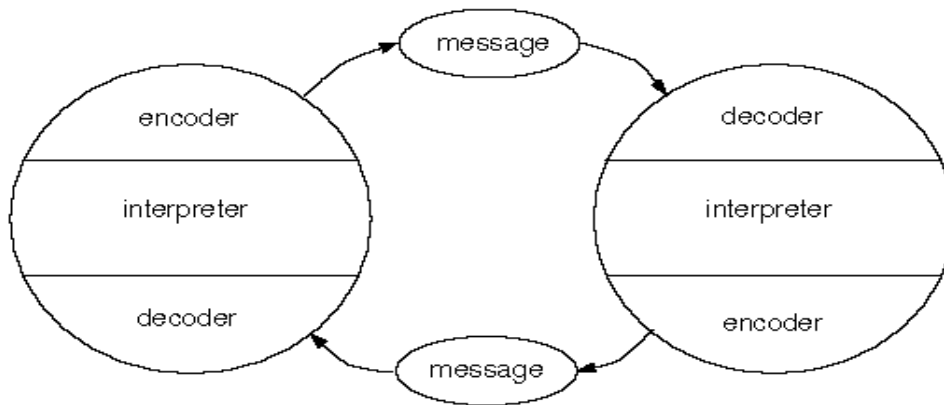

Fig.8 Schramm's communication model

This model shows more explicitly that human communication is a circle rather than a one-way event. Each part of the communication process is perceived as both an encoder and a decoder. In addition, each part acts as an interpreter, understanding the messages he or she receives in a somewhat different way. This is because we are affected by a *field of experience*. Field of experience represents an individual's beliefs, values and experiences. If the source's and destination's fields of experience overlap, communication can take place. If there is no such an overlap, or only a small area is in common, communication is difficult if not impossible.

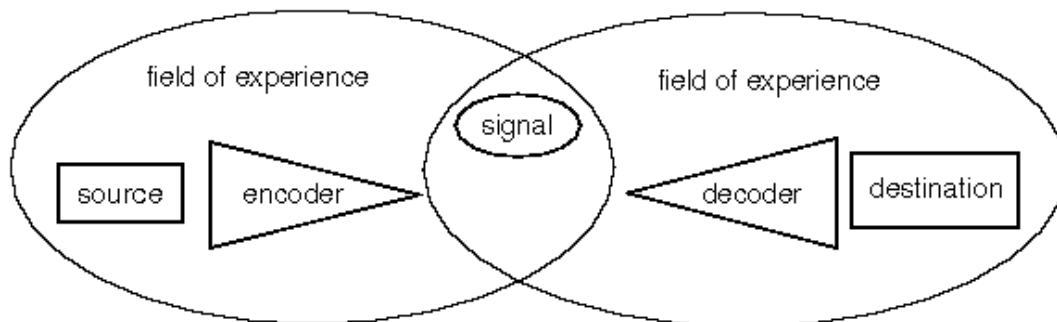

Fig.9 Schramm's field of experience

W. Schramm suggests that the message can be complicated by different meanings learned by different people. Meanings can be *denotative* or *connotative*. Denotative meanings are common or dictionary meanings and can be roughly the same for most people. Connotative meanings are emotional or evaluative and are based on personal experience. Other characteristics of messages that impact communication between two individuals are: intonation and pitch patterns, accents, facial expressions, quality of voice, and gestures.

f. The Rileys' model

John and Matilda Riley, a husband and a wife, pointed out the importance of the sociological view in communication. The two sociologists say such a view would fit together many messages and individual reactions to them within an integrated social structure and process. The Rileys developed a model to illustrate these sociological implications in communication.

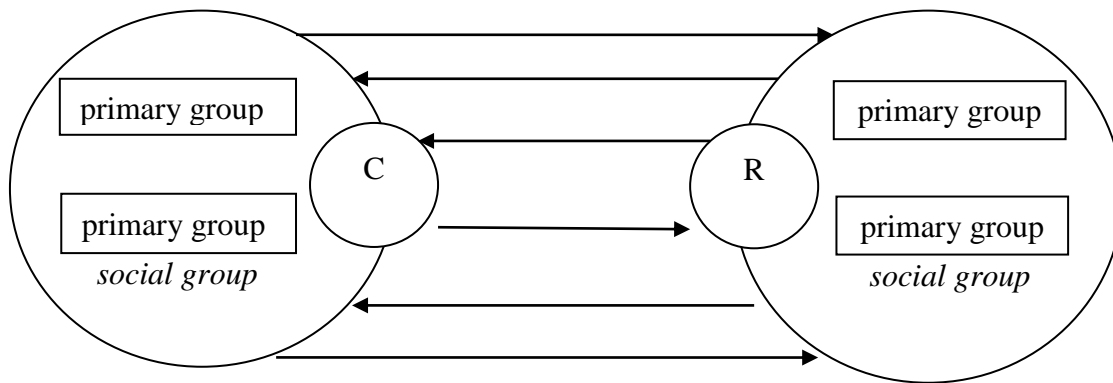

Fig.10 The Rileys' model of communication

The model indicates that communicator (C) emerges as part of a larger pattern, sending messages in accordance with the expectations and actions of other persons and groups within the same social structure. This is also true of the receiver (R) in the communication process. In addition, both the communicator and receiver are parts of an overall social system. Within such an all-embracing system, the communication process is seen as a part of a larger social process, both affecting it and being, in turn, affected by it. The model clearly illustrates that communication is a two-way process. The important point the Rileys' model suggests is that we send messages as members of certain primary groups and that our receivers receive our messages as members of primary groups as well.

g. Berlo's model

Another communication model we are going to consider is the one, developed by David K. Berlo, a communication theorist and consultant. In his book *The Process of Communication*, Berlo points out the importance of the psychological view in communication. The four parts of Berlo's model are, no surprises here, *source, message, channel, receiver*.

The first part of this communication model is *the source*. All communication must come from some source. The source might be one person, a group of people, or a company, organization, or institution such as the University of Uzhhorod. Several things determine how a source operates in the communication process. They include the source's communication skills: abilities to think, write, draw, speak. They also

include attitudes toward the audience, the subject matter, or toward any other factor pertinent to the situation. Knowledge of the subject, the audience, the situation and other background also influences the way the source operates.

Message has to do with the package of information to be sent by the source. The code or language must be chosen. In general, we think of the code in terms of natural languages (English, Spanish, German, Chinese and others). Sometimes we use other languages – music, art, gestures.

Channel can be thought of as a sense – smelling, tasting, feeling, hearing, seeing. Sometimes it is preferable to think of the channel as the method with the help of which the message will be transmitted: telegraph, newspaper, radio, letter, poster or other media. The kind and number of channels to use may depend largely on purpose. In general, the more you can use and the more you tailor your message to the people "receiving" each channel, the more effective your message is.

Receiver becomes the final link in the communication process. The receiver is the person or persons who make up the audience of your message. All of the factors that determine how a source will operate are applied to the receiver. The receiver may have more or less knowledge than the source. Sociocultural context could be different in many ways from that of the source, but social background, education, friends, salary, culture would still be involved. Each will affect the receiver's understanding of the message. Messages sometimes fail to accomplish their purpose for many reasons. Frequently the source is unaware of receivers and how they view things. Certain channels may not be very effective under certain circumstances.

h. Katz and Lazarsfeld's model (two-step flow of communication)

The two-step flow of communication hypothesis was first introduced by Paul Lazarsfeld, Bernard Berelson, and Hazel Gaudet in *The People's Choice*, a 1944 study focused on the process of decision-making during a Presidential election campaign. These researchers expected to find empirical support for the direct influence of media messages on voting intentions. They were surprised to discover, however, that informal, personal contacts were mentioned far more frequently than exposure to radio or newspaper as sources of influence on voting behavior. Armed with these data, Katz and Lazarsfeld developed the two-step flow theory of mass communication (Fig.11). This theory asserts that information from the media moves in two distinct stages. First, individuals (opinion leaders) who pay close attention to the mass media and its messages receive the information. Opinion leaders pass on their own interpretations in addition to the actual media content. The term 'personal influence' was coined to refer to the process intervening between the media's direct message and the audience's ultimate reaction to that message. Opinion leaders are quite influential in getting people to change their attitudes and behaviors and are quite similar to those they influence. The two-step flow theory has improved our understanding of how the mass media influence decision making. The theory refined the ability to predict the influence of media messages on audience behavior, and it helped explain why certain media campaigns may have failed to alter audience

attitudes and behavior. The two-step flow theory gave way to the multi-step flow theory of mass communication.

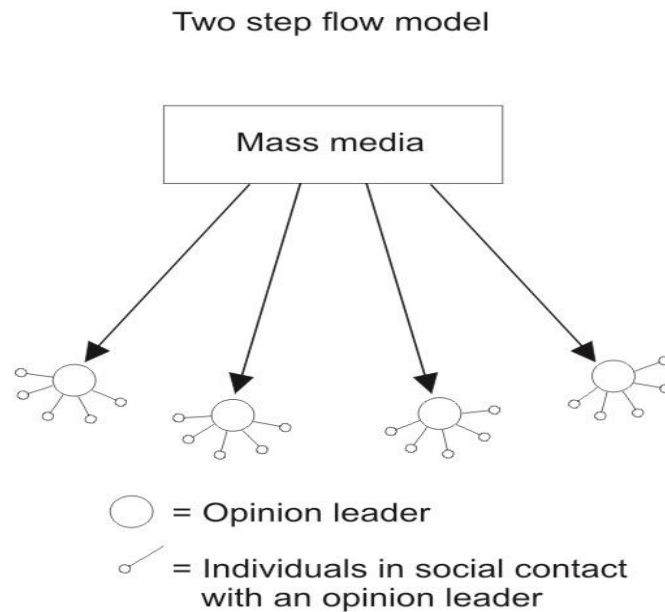

Fig. 11 Katz and Lazarsfeld's model of communication

Let us sum up the important thoughts illustrated by each model: **Aristotle:** The receiver holds the key to success. **Lasswell:** An effect must be achieved if communication takes place. **Shannon and Weaver:** Semantic noise can be a major communication barrier. **Schramm:** Overlapping experiences make it easier to communicate successfully. **The Rileys:** Membership in primary groups affects how messages are sent

and received. **Berlo:** Several important factors must be considered relating to source, message, channel, receiver. **Katz and Lazarsfeld:** Information from the media moves in two distinct stages.

Self-check test

1. Describe Aristotelian model of communication.
2. What are the components of Lasswell's model?
3. What is semantic noise?
4. What are the components of R.Jacobson's model?
5. What is field of experience?
6. Describe the Rileys' model of communication.
7. Characterize the components of Berlo's model of communication.
8. What makes the essence of Katz and Lazarsfeld's model of communication?

Recommended Readings

1. Aristotle. Rhetoric and Poetics. – New York: Random House. – 1994.

2. Berger A. *Essentials of Mass Communication Theory*. – London: Sage, 1995.
3. Berko R. *Communicating*. – Boston, MA: Pearson Education, Inc., 2018. – P. 9-12.
4. Berlo D. *The Process of Communication*. – New York: Holt, Rinehart, and Winston, 1960.
5. Brent R., Stewart L. *Communication and Human Behavior*, 4th edition. – Needham Heights, MA: Allyn & Bacon. – 1998.
6. Curran J., Gurevitch M. *Mass Media and Society*. 4th ed. – London: Hodder Arnold, 2005.
7. Dance F. *Human Communication Theory: Original Essays*. – New York: Holt, 2007.
8. Katz E., Lazarsfeld P. *Personal Influence*. – New York: The Free Press, 1955.
9. Katz E. *The two-step flow of communication*. – New York: The Free Press, 1973. – P. 175-193.
10. Lazarsfeld P.F., Berelson B., Gaudet H. *The people's choice: How the voter makes up his mind in a presidential campaign*. – New York: Columbia University Press, 1944.
11. McQuail D., Windahl S. *Communication Models for the Study of Mass Communications*. – London: Longman, 1993.
12. Schramm W. *How Communication Works / The Process and Effects of Communication* / Urbana: University of Illinois Press, 1954. – P. 3-26.
13. Shannon C., Weaver W. *The Mathematical Theory of Communication*. – Urbana: University of Illinois Press, 2009.

Lecture 4

Types of communication

Plan

1. *Preliminary remarks.*
2. *Communication types.*
 - 2.a. *Verbal communication.*
 - 2.b. *Non-verbal communication. Preliminary remarks.*
 - 2.c. *Interaction of verbal and non-verbal communication.*

1. *Preliminary remarks*

Humans live their daily lives through a series of communications without which nothing in this world would be achievable. The medium through which men convey their innermost thoughts and will are expressed through a variety of communication channels. When we take a closer look at the number of expressions and responses that human beings make everyday we begin to understand the types of communication that exists in the world. The types of communication that the humans use come in different forms. It may be verbal, which means that there is the use of words, and nonverbal which denotes communication through actions and behaviors. It can also denote whether an event is formal or non-formal. The types of communication used indicate that some things can be described with the use of words or paragraphs. There are also things that words could not fully describe. Sometimes only an action or gesture could express the real meaning that the speaker is trying to convey. Different types of communication open your mind to all the things that are happening daily in our lives. If a person knows only verbal communication and has no inkling that nonverbal communication is possible, then he/she is an alien in that realm of communication. Without the existence of a variety of communication options, your life would be a less rich experience. Knowing only the verbal side or the nonverbal side may lead the one to miss out the things you want to do.

The types of communication do not only happen in the world of humans. Animals also have their own types of communication. Even the birds and the fish have their methods of communicating. Even plants have their own ways of talking to one another. We can assume that all living creatures have their own forms of communication which are understandable only to them. We may never fully understand the communication of birds and other animals. We can only assume what is being conveyed but never fully comprehend it. This is the same with people. We would never fully relate to the way that members of other species communicate with each other. Learning various types of communication available to us, enables us to enhance our communication skills, whether verbal or nonverbal. It is important for a child to learn the way that his or her parents speak so that they can also communicate in return. It has often been said that babies understand some verbal communication before birth. However, research shows that a child you don't talk to, will, to a large extent, lose the ability to learn to speak after they reach a certain age. To expound

further on the types of communication is to make a direct inquiry into the heart of every known language. Isn't it that because of the existence of the types of communication, a French man marries an American woman? Even without words from the very beginning, he just looked her way, she looks his way, and it ended in tying the knot. No words were used here, just a look, and maybe a smile. The types of communication also enable one to distinguish the differences between a simple meeting and the big meeting. It helps the person know when to make a "Morning!" and when to say "Good morning ma'am." In this case there are only types of communication, the formal and informal. Formal communication is done in cases where a formal tone is needed and adherence to certain formal rules or principles in communication must follow. These are seen in business meetings, business correspondence, memos, official letters, government related documents, and so on. Informal communication, on the other hand, can be used in communicating with friends, families, peers, etc. It has no standard format. All types of communication present in this world are unique and it makes everyone special and different from one another. It creates harmony and enables the expression of thoughts and emotions.

2. Communications types

2.a. Verbal communication

Scholars in this field usually use a strict sense of the term "*verbal*", meaning "*of or concerned with words*," and do not use "*verbal communication*" as a synonym for oral or spoken communication. Thus, vocal sounds, which are not considered to be words, such as a grunt, or singing a wordless note, are nonverbal. Sign languages and writing are generally understood as forms of verbal communication, as both make use of words — although like speech, both may contain paralinguistic elements and often occur alongside nonverbal messages. A sign language (also signed language) is a language which, instead of acoustically conveyed sound patterns, uses visually transmitted sign patterns (manual communication, body language) to convey meaning — simultaneously combining hand shapes, orientation and movement of the hands, arms or body, and facial expressions to fluidly express a speaker's thoughts.

2.b. Nonverbal communication. Preliminary remarks.

Nonverbal communication is usually understood as the process of communication through sending and receiving wordless messages. Such messages can be communicated through gestures, body language or posture, facial expression, eye contact, object communication such as clothing, hairstyles or even architecture, symbols and infographics. Speech may also contain nonverbal elements known as paralinguage, including voice quality, emotion and speaking style, as well as prosodic features such as rhythm, intonation and stress. Likewise, written texts have nonverbal elements such as handwriting style, spatial arrangement of words, or the use of emoticons.

According to Joseph H. Di Leo language comprises all forms of communication: crying, facial expression, gestures, touching, yelling, and also speech and writing. Every thing speaks in the process of communication including material objects and physical space but only speech sounds or verbal production is observed, non-verbal cannot, which is a valuable component of communication. It enhances the meaning of words. A speaker can raise the interest and curiosity of the listeners with the help of the elements of non-verbal communication, which can occur through any sensory channel — sight, sound, smell, touch or taste. This type of communication is very important as when we speak or listen, our attention is focused on words rather than body language, but our judgement includes both. Very often people’s actions speak louder than the words. We can deceive others much more easily with the words than we can do with their bodies. If words are relatively easy to control, body language, facial expressions, and vocal characteristics are not. By paying attention to the nonverbal signals, one can detect deception or affirm a speaker's honesty.

Because nonverbal communication is so reliable, people generally have more faith in nonverbal cues than they do in verbal messages. If a person says one thing, but transmits a conflicting message nonverbally, listeners almost invariably believe the nonverbal signal. Chances are, if you can read other people nonverbal messages correctly, you can interpret their underlying attitudes and intentions and respond appropriately.

Albert Mehrabian, a pioneer researcher of body language in the 1970s, found that the total impact of a message is about 7% verbal (words only) and 38% vocal (including tone of voice, inflection and other sounds) and 55% non-verbal.

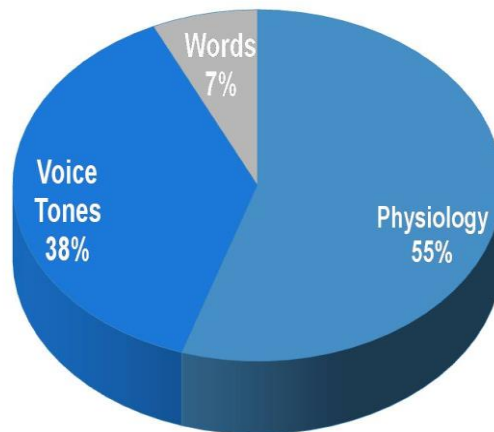

Fig. 1 The correlation of verbal and non-verbal communication

It has been revealed that 93% of communication is non-verbal. Nowadays studies range across a number of fields. Participating in a significant part of human interaction nonverbal communication attracted the attention of scientists in the field of social psychology, general psychology, therapy etc.

Speech may also contain nonverbal elements known as paralanguage, including voice quality, emotion and speaking style, as well as prosodic features such as rhythm, intonation and stress. Written texts have nonverbal elements such as handwriting style, spatial arrangement of words, or the use of emoticons.

D. Givens states that tone of voice reflects psychological arousal, emotion, and mood. It may also carry social information, as in a sarcastic, superior, or submissive manner of speaking.

The first scientific study of nonverbal communication was Charles Darwin's book *The Expression of the Emotions in Man and Animals*. Scientist was of the opinion that all mammals show emotion reliably in their faces.

It is not an easy task to define non-verbal communication, because of different approaches to its consideration. Owing to the fact that we are able to “read” nonverbal signs, David Givens gives the following definition to a nonverbal sign:

1. A body movement, posture, or material artifact which encodes or influences a concept, motivation, or mood (thus, a gesture is neither matter nor energy, but information).

2. In its most generic sense, a gesture is a sign, signal, or cue used to communicate in connection with, or apart from, words.

3. Gestures include facial expressions (e.g., eyebrow-raise, smile), clothing cues (e.g., business suit, neckwear), body movements (e.g., palm-down, shoulder-shrug), and postures (e.g., angular distance). Many consumer products (e.g., big Mac®, Vehicular Grille, Vehicular Stripe) contain messaging features designed to communicate as signs, and may be decoded as gestures as well.

4. Those wordless forms of communication omitted from a written transcript.

Anthropologist Ray Birdwhistell pioneered the original study of nonverbal communication what he called ‘Kinesics’. He carried out some research into the amount of non-verbal communication, taking place between humans. In his opinion the average person actually speaks words for about ten or eleven minutes a day and that the average sentence takes only 2.5 seconds, and at the same amount of time a person can make and recognize around 250,000 facial expressions.

James O’Rourke states that “... communication experts have established the fact that less than a third of the meaning transferred from one person to another in a personal conversation comes from the words that are spoken. The majority of meaning comes from nonverbal sources, including body movement; eye contact; gestures; posture; and vocal tone, pitch, pacing, and phrasing. Other messages come from our clothing, our use of time, and literally dozens of other nonverbal categories”. The author further remarks that nonverbal communication is widely regarded as the transference of meaning without the usage of words. In other words, nonverbal communication considers those actions, objects, and contexts that either communicate directly or facilitate communication without using words. The consideration of the effects of verbal and nonverbal behavior separately is never easy, largely because they tend to reinforce each other, contradict each other, or are in some way about each other.

Ch. Barber states: “When a man nods his head to indicate assent (or, in some cultures, refusal), the gesture is arbitrary and therefore symbolic. Weeping is a sign of sorrow, and blushing is a sign of shame, but these signs are caused by the emotional states in question, and so are not arbitrary or symbolic”.

However, much of the study of nonverbal communication has focused on face-to-face interaction, where it can be classified into three principal areas: environmental conditions where communication takes place, physical characteristics of the communicators, and behaviors of communicators during interaction. This idea has been also stressed by Rashid Rashad who says that: “Most social psychologists will tell you that nonverbal communication makes up about two-thirds of all communication between two people or between one speaker and a group of listeners”.

Nonverbal communication can deliver a message with the help of verbal and correct body signals. Body language includes physical features, both changeable and unchangeable, your gestures and signals you send to others at a conscience and unconscious level, and the space that you use when communicating with others [the same p. 79]. First encounters or interactions with another person strongly affect a person’s lifestyle. People are more likely to believe that the first things they learn are the truth. When the other person or group is absorbing the message they are focused on the entire environment around them, meaning, the other person uses all five senses in the interaction. According to D.Bull: “Sight makes up 83% of the impact on the brain of information from the senses during a visual presentation. Taste makes up 1%, hearing makes up 11%, smell 3% and touch 2%”.

While much nonverbal communication is based on arbitrary symbols, which differ from culture to culture, a large proportion is also to some extent iconic and may be universally understood. Paul Ekman's influential in 1960s studies of facial expression determined that expressions of anger, disgust, fear, joy, sadness and surprise are universal.

2.b.1. Gesture



A wink is a type of gesture.

A *gesture* is a form of non-verbal communication made with a part of the body used instead of or in combination with *verbal communication*. The language of gesture allows individuals to express a variety of feelings and thoughts, from

contempt and hostility to approval and affection. Most people use gestures and body language in addition to words when they speak. The use of gesture as language by some ethnic groups is more common than in others, and the amount of such gesturing that is considered culturally acceptable varies from one location to the next. Gestures do not have invariable or universal meanings. Even simple gestures like pointing at someone can cause offense if it is not done correctly. In the USA and western European countries it is very common for people to point with an extended finger, but in Asia this is considered very rude and it is safer to use the whole hand. Psychologist Paul Ekman suggested that gestures could be categorised into five types: *emblems*, *illustrators*, *affect displays*, *regulators*, and *adaptors*:

- *emblems* are gestures with direct verbal translations, such as a goodbye wave;
- *illustrators* are gestures that depict what is said verbally, such as turning an imaginary steering wheel while talking about driving;
- an *affect display* is a gesture that conveys emotions, like a smile;
- *regulators* are gestures that control interaction;
- and, finally, an *adaptor* is a gesture that facilitates the release of bodily tension, such as quickly moving one's leg.

2.b.2. Body language

Body language is a form of non-verbal communication, which consists of body posture, gestures, facial expressions, and eye movements. Humans move their bodies when communicating because, as research has shown, it helps "ease the mental effort when communication is difficult." Physical expressions reveal many things about the person using them. For example, gestures can emphasize a point or relay a message, posture can reveal boredom or great interest, and touch can convey encouragement or caution. Humans send and interpret such signals subconsciously. John Borg attests that 93 percent of human communication consists of body language and paralinguistic cues, while only 7% of communication consists of words themselves. However, Albert Mehrabian, the researcher whose work is the source of these statistics, has stated that this is a misunderstanding of the findings. Others assert that research has suggested that between 60 and 70 percent of all meaning is derived from nonverbal behavior. Body language may provide clues as to the attitude or state of mind of a person. For example, it may indicate aggression, attentiveness, boredom, relaxed state, pleasure, amusement, and intoxication, among many other cues. The technique of "reading" people is used frequently. For example, the idea of mirroring body language to put people at ease is commonly used in interviews. Mirroring the body language of someone else indicates that they are understood. Body language signals may have a goal other than communication. Both people would keep this in mind. Observers limit the weight they place on non-verbal cues. Signalers clarify their signals to indicate the biological origin of their actions. Examples would include yawning (sleepiness), showing lack of interest (sexual interest/survival interest), attempts to change the topic (fight or flight drivers).

Physical expressions like waving, pointing, touching and slouching are all forms of nonverbal communication.

Some examples of body movements

- One of the most basic and powerful body-language signals is when a person *crosses his or her arms across the chest*. This can indicate that a person is putting up an unconscious barrier between themselves and others. It can also indicate that the person's arms are cold, which would be clarified by rubbing the arms or huddling. When the overall situation is amicable, it can mean that a person is thinking deeply about what is being discussed. But in a serious or confrontational situation it can mean that a person is expressing opposition. This is especially so if the person is leaning away from the speaker. A harsh or blank facial expression often indicates outright hostility.
- Consistent *eye contact* can indicate that a person is thinking positively of what the speaker is saying. It can also mean that the other person doesn't trust the speaker enough to "take their eyes off" the speaker. Lack of eye contact can indicate negativity. On the other hand, individuals with anxiety disorders are often unable to make eye contact without discomfort. Eye contact can also be a secondary and misleading gesture because cultural norms about it vary widely. If a person is looking at you, but is making the arms-across-chest signal, the eye contact could be indicative that something is bothering the person, and that he/she wants to talk about it. Or, if while making direct eye contact, a person is fiddling with something, even while directly looking at you, it could indicate the attention is elsewhere. Also, there are three standard areas that a person will look which represent different states of being. If the person looks from one eye to the other then to the forehead, it is a sign that they are taking an authoritative position. If they move from one eye to the other then to the nose, that signals that they are engaging in what they consider to be a "level conversation" with neither party holding superiority. The last case is from one eye to the other and then down to the lips. This is a strong indication of romantic feelings.
- Disbelief is often indicated by *averted gaze, or by touching the ear or scratching the chin*. When a person is not being convinced by what someone is saying, the attention invariably wanders, and the eyes will stare away for an extended period.
- Boredom is indicated by the *head tilting to one side, or by the eyes looking straight at the speaker but becoming slightly unfocused*. A head tilt may also indicate a sore neck or Amblyopia, and unfocused eyes may indicate ocular problems in the listener.
- Interest can be indicated through *posture or extended eye contact, such as standing and listening properly*.
- Deceit or the act of withholding information can sometimes be indicated by *touching the face* during conversation. *Excessive blinking* is a well-known indicator of someone who is lying. Recently, evidence has surfaced that the

absence of blinking can also represent lying as a more reliable factor than excessive blinking.

People use and understand body language differently. Interpreting their gestures and facial expressions in the context of normal body language usually leads to misunderstandings and misinterpretations (especially if body language is given priority over spoken language). It should also be stated that people from different cultures can interpret body language in different ways.

2.b.3. Haptics



A high five is an example of communicative touch.

Haptics is the study of touching as one of the forms of nonverbal communication. Touches that can be defined as communication include handshakes, holding hands, kissing (cheek, lips, hands), back slapping, high fives, a pat on the shoulder, and brushing an arm. The meaning conveyed from touches is highly dependent upon the context of the situation, the relationship between communicators, and the manner of touch.

2.b.4. Clothing and bodily characteristics



Uniforms have both a functional and a communicative purpose. This man's clothes identify him as male and a police officer; his badges and shoulder sleeve insignia give information about his job and rank. Elements such as physique, height, weight, hair, skin color, gender, odors, and clothing send nonverbal messages during interaction. Research into height has generally found that taller people are perceived

as being more impressive. Melamed & Bozionelos (1992) studied a sample of managers in the UK and found that height was a key factor affecting those who were promoted. Often people try to make themselves taller – for example, standing on a platform – when they want to make more of an impact with their speaking. In most cultures, gender differentiation of clothing is considered appropriate for men and women. The differences are in styles, colors and fabrics. In Western societies skirts, dresses and high-heeled shoes are usually seen as women's clothing, while neckties are usually seen as men's clothing. Trousers were once seen as exclusively male clothing, but are nowadays worn by both genders. Male clothes are often more practical (that is, they can function well under a wide variety of situations), but a wider range of clothing styles are available for females. Males are typically allowed to bare their chests in a greater variety of public places. It is generally acceptable for a woman to wear traditionally male clothing, while the converse is unusual. In some cultures, sumptuary laws regulate what men and women are required to wear. Islam requires women to wear more modest forms of attire, usually hijab. What qualifies as "modest" varies in different Muslim societies; however, women are usually required to cover more of their bodies than men are. Articles of clothing worn by Muslim women for purposes of modesty range from the headscarf to the burqa. Men may sometimes choose to wear men's skirts such as togas or kilts, especially on ceremonial occasions. Such garments were (in previous times) often worn as normal daily clothing by men. Compared to men's clothing, women's clothing tends to be more attractive, often intended to be looked at by men. In modern industrialized nations, women are more likely to wear makeup, jewelry, and colorful clothing, while in very traditional cultures women are protected from men's gazes by modest dress. In some societies, clothing may be used to indicate rank or status. In ancient Rome, for example, only senators were permitted to wear garments dyed with Tyrian purple. In traditional Hawaiian society only high-ranking chiefs could wear feather cloaks and palaoa or carved whale teeth. Under the Travancore Kingdom of Kerala, (India), lower caste women had to pay a tax for the right to cover their upper body. In China, before the establishment of the republic, only the emperor could wear yellow. History provides many examples of elaborate sumptuary laws that regulated what people could wear. In societies without such laws, which include most modern societies, social status is instead signaled by the purchase of rare or luxury items that are limited by cost to those with wealth or status. In addition, peer pressure influences clothing choice.

2.b.5. Physical environment

Environmental factors such as furniture, architectural style, interior decorating, lighting conditions, colors, temperature, noise, and music affect the behavior of communicators during interaction. Environmental conditions can alter the choices of words or actions that communicators use to accomplish their communicative objective.

2.b.5.1. Proxemics

Proxemics is the study of how people use and perceive the physical space around them. The space between the sender and the receiver of the message influences the way the message is interpreted. The perception and use of space varies significantly across cultures and different settings within cultures. Space in nonverbal communication may be divided into four main categories: intimate, social, personal, and public. The distance between communicators will also depend on sex, status, and social roles. Proxemics was first developed by Edward T. Hall during the 1950s and 60s. Hall's studies were inspired by earlier studies of how animals demonstrate territoriality. The term territoriality is still used in the study of proxemics. Hargie & Dickson identify 4 such territories:

- 1) Primary territory: this refers to an area that is associated with someone who has exclusive use of it, e.g. a house that others cannot enter without the owner's permission.
- 2) Secondary territory: unlike the previous type, there is no "right" to occupancy, but people may still feel some degree of ownership of a particular space, e.g. someone may sit in the same seat on train every day and feel aggrieved if someone else sits there.
- 3) Public territory: this refers to an area that is available to all, but only for a set period, such as a parking space or a seat in a library. Although people have only a limited claim over that space, they often exceed that claim. For example, it was found that people take longer to leave a parking space when someone is waiting to take that space.
- 4) Interaction territory: this is the space created by others when they are interacting. For example, when a group is talking to each other on a footpath, others will walk around the group rather than disturb it.

2.b.5.2. Chronemics

Chronemics is the study of the use of time in nonverbal communication. The way we perceive time, structure our time and react to time is a powerful communication tool and helps set the stage for communication. Time perceptions include punctuality and willingness to wait, the speed of speech and how long people are willing to listen. The timing and frequency of an action as well as the tempo and rhythm of communication within an interaction contributes to the interpretation of nonverbal messages. Gudykunst & Ting-Toomey (1988) identified 2 dominant time patterns:

- Monochronic time schedule (M-time): Time is seen as being very important and it is characterised by a linear pattern where the emphasis is on the use of time schedules and appointments. Time is viewed as something that can be

controlled or wasted by individuals, and people tend to do one thing at a time. The M-pattern is typically found in North America and Northern Europe.

- Polychronic time schedule (P-time): Personal involvement is more important than schedules where the emphasis lies on personal relationships rather than keeping appointments on time. This is the usual pattern that is typically found in Latin America and the Middle East.

2.b.6. Paralanguage

Paralanguage (sometimes called vocalics) is the study of nonverbal cues of the voice. Various acoustic properties of speech such as tone, pitch and accent, collectively known as prosody, can all give off nonverbal cues. Paralanguage may change the meaning of words. George L. Trager developed a classification system which consists of the *voice set*, *voice qualities*, and *vocalization*.

- The *voice set* is the context in which the speaker is speaking. This can include the situation, gender, mood, age and a person's culture.
- The *voice qualities* are volume, pitch, tempo, rhythm, articulation, resonance, nasality, and accent. They give each individual a unique "voice print".
- *Vocalization* consists of three subsections: *characterizers*, *qualifiers* and *segregates*. *Characterizers* are emotions expressed while speaking, such as laughing, crying, and yawning. A *voice qualifier* is the style of delivering a message – for example, yelling "Hey stop that!", as opposed to whispering "Hey stop that". *Vocal segregates* such as "uh-huh" notify the speaker that the listener is listening.

2.b.7. facial expression

A facial expression results from one or more motions or positions of the muscles of the face. These movements convey the emotional state of the individual to the observers. They are a primary means of conveying social information among humans, but also occur in most other mammals and some other animal species. Humans can adopt a facial expression as a voluntary action. However, because expressions are closely tied to emotion, they are more often involuntary. It can be nearly impossible to avoid expressions for certain emotions, even when it would be strongly desirable to do so; a person who is trying to avoid insult to an individual he or she finds highly unattractive might nevertheless show a brief expression of disgust before being able to reassume a neutral expression. The close link between emotion and expression can also work in other direction; it has been observed that voluntarily assuming an expression can actually cause the associated emotion.

2.b.8. eye gaze

The study of the role of eyes in nonverbal communication is sometimes referred to as "oculesics". Eye contact can indicate interest, attention, and

involvement. Gaze is comprised of the actions of looking while talking, looking while listening, amount of gaze, and frequency of glances, patterns of fixation, pupil dilation, and blink rate. In human beings eye contact is a form of nonverbal communication and is thought to have a large influence on social behavior. Coined in the early to mid-1960s, the term has come in the West to define the act as a meaningful and important sign of confidence and social communication. The customs and significance of eye contact vary widely between cultures, with religious and social differences often altering its meaning greatly. In the Islamic faith, Muslims often lower their gaze and try not to focus on the opposite sex's faces and eyes after the initial first eye contact, other than their legitimate partners or family members, in order to avoid potential unwanted desires. Lustful glances to those of the opposite sex, young or adult, are also prohibited. This means that eye contact between any man and woman is allowed only for a second or two. This is a must in most Islamic schools, with some exceptions depending on the case, like when teaching, testifying, or looking at a girl for marriage. If allowed, it is only allowed under the general rule: "No-Desire", clean eye-contact. Otherwise, it is not allowed, and considered "adultery of the eyes". Japanese children are taught in school to direct their gaze at the region of their teacher's Adam's apple or tie knot. As adults, Japanese lower their eyes when speaking to a superior as a gesture of respect. In many cultures, such as East Asia and Nigeria, it is respectful not to look the dominant person in the eye, but in Western culture this can be interpreted as being "shifty-eyed", and the person judged badly because "he wouldn't look me in the eye"; references such as "shifty-eyed" can refer to suspicions regarding an individual's unrevealed intentions or thoughts. Nevertheless, the seeking of constant unbroken eye contact by the other participant in a conversation can often be considered overbearing or distracting by many even in western cultures, possibly on an instinctive or subconscious level.

Self-check test

1. What is verbal communication?
2. What was the first scientific study of non-verbal communication?
3. What is a gesture?
4. According to P.Ekman gestures could be categorized into... . Continue the sentence.
5. Describe body language.
6. What is haptics?
7. What is physical environment?
8. What is proxemics?
9. "Proxemics was first developed by... ". Continue the sentence.
10. What are 4 territories identified by Hargie and Dickson?
11. What is chronemics?
12. What is monochromic time schedule?
13. What is polychromic time schedule?
14. What is paralanguage?

15. What is voice set?

Recommended Readings

1. Balter M. Clothes Make the (Hu) Man. – Science, 2019. – P. 325(5946):1329.
2. Borg J. Body Language: 7 Easy Lessons to Master the Silent Language.– Prentice Hall-life, 2018.
3. Ekman P., & Friesen W. Nonverbal leakage and clues to deception: Psychiatry, vol. 32, 1969. – P. 88-106.
4. Ekman P., Friesen W. Unmasking the Face: A guide to recognize emotions from facial clues. Prentice-Hall, Inc. 2005.
5. Ekman P., Friesen W., Hager J. Facial Action Coding System: Investigator's Guide. — 2nd edition. — Salt Lake City: Research Nexus eBook, 2002.
6. Ekman P. Emotions Revealed — Recognizing Faces and Feelings to Improve Communication and Emotional Life. — 2nd edition. — 2017.
7. Flugel C. The Psychology of Clothes / International Psycho-analytical Library. – N.18. – New York: AMS Press, 1976.
8. Hall E. The Silent Language. – Garden City, N.Y.: Doubleday, 1959.
9. Hall E. The Hidden Dimension. – Garden City, N.Y.: Doubleday, 1966.
10. Hall E. Beyond Culture. – Garden City, N.Y.: Anchor Press, 1976.
11. Hargie O. Skilled Interpersonal Communication: Research, Theory and Practice. – Hove: Routledge, 2014.
12. Gudykunst W., Stella T. Culture and Interpersonal Communication. – L.: Newbury Park, 1988.
13. Krueger J. Nonverbal Communication. – New York, 2008.
14. Mehrabian A. Silent Messages – A Wealth of Information About Nonverbal Communication (Body Language) / Personality & Emotion Tests & Software: Psychological Books & Articles of Popular Interest. – Los Angeles, CA, 2019.
15. Melamed J., Bozionelos N. Managerial promotion and height. Psychological Reports, 1992. – P. 587–593.
16. Newburgh H. Physiology of Heat Regulation and the Science of Clothing. – New York & London: Hafner Publishing, 1998.
17. Trager L. Paralanguage: A first approximation / Studies in Linguistics / 1958. – P. 1-12.

Lecture 5

Functions of communication

Plan

1. Functions of verbal communication.

1.a. Phatic communication.

1.b. Self-other understanding and establishing meaningful relationships.

1.c. Instrumental function.

1.d. Affective function.

1.e. Catharsis.

1.f. Magic function.

1.g. Ritual function.

2. Functions of nonverbal communication.

1. Functions of verbal communication

1.a. Phatic communicaton

Every communication experience serves one or more functions. It can help us to discover who we are, aid us in establishing meaningful relationships or prompt us to examine and try to change either our own attitude and behaviour or the attitude and behavior of others. Small talk, uninspired greetings and idle chatter form the fundamental type of communication that Bronislaw Malinowski called phatic communion. To show that we welcome communication, that we are friendly or that we at least acknowledge the presence of another person, we exchange words like, "*How are you?*" or "*Hello*" or "*Nice day*". There may be variations, based on geography "*Howdy!*" or familiarity "*Hi ya, Baby!*" or specific conditions "*Cold enough for ya?*". In phatic communication the specific words exchanged are not important. The only rule that is applied to phatic communion is that "the subject" of communication is such that each party can say something about it. That is why everybody talks about the weather. The important thing is to talk – and this is why so much of phatic communication begins with a question, for a question requires a reply. We do not request specific information in phatic communion and we are not expected to reply with precision or accuracy. If we are greeted with a "*How are you?*" we do not reply as we might if our doctor asked the question. When we are precise, the result is likely to be humorous. Members of secret organizations sometimes speak in code when they meet to determine whether each knows the password, special handshake or other symbol. If the answer to the secret question is not precise, then the other is not regarded as a brother Mason or sister Theta or whatever, and subsequent communication will be prevented. Such coded phatic communion dates from times when members of such organizations might be persecuted, if discovered. Among some secret organizations today the reverse seems to be true. The coded greeting is often expressed loudly, more for the benefit of the outsiders than for the "secret" members. Phatic

communication is usually the most casual, even careless form of communication. The stories of persons passing through receiving lines and saying something like "*I have just killed my mother-in-law*" which is met with a smile and a "*Fine, I hope you're enjoying yourself*" are well-known. They illustrate what little is attached to phatic communication, so little that the speaker is not even listened to. In such extreme cases, however, we may wonder to what extent the channels of communication have been opened after that exchange of noises. In any case, it seems that we prefer some noise to no noise.

1.b. Self-other understanding and establishing meaningful relationships

Another key function of communication is self-other understanding. When you get to know another person, you also get to know oneself, you learn how others affect you. In other words, we depend on communication to develop self-awareness. Communication theorist T. Hora puts it this way: "To understand himself man needs to be understood by another. To be understood by another he needs to understand the other". We need feedback from others all the time and others are constantly in need of feedback from us. Interpersonal, small-group and public communication contact offer us numerous opportunities for self-other discovery. Through communication processes we are able to learn why we are trusting or untrusting, whether we can make our thoughts and feelings clear, under what conditions we have the power to influence others, and whether we can effectively make decisions and resolve conflicts and problems. In order to build a relationship we cannot be concerned about ourselves but must consider the needs and wants of others. It is through effective interpersonal, small-group and public communication contacts that our basic social needs are met. Communication offers each of us the chance to satisfy what psychologist William Schutz calls our "*needs for inclusion, contact, and affection*". The *need for inclusion* is our need to be with others, our need for social contact. We like to feel that others accept and value us and we want to feel like a full partner in a relationship. *The need for control* is our need to feel that we are capable and responsible, that we are able to deal with and manage our environment. We like to feel that we can influence others. *The need for affection* is our need to express and receive love. Since communication allows each of these needs to be met if we are able to communicate meaningfully with others we are less likely to feel unwanted, unloved or incapable. During interpersonal, small-group and public communication interactions individuals have ample opportunities to influence each other. We spend much time trying to persuade one another to think as "we" think, do what "we" do, like what "we" like. Sometimes our efforts meet with success, and sometimes they do not. In any case our persuasion experiences allow each of us the change to influence another so that we may try to realize our goals.

1.c. Instrumental function

When we say something and something happens as a result of our speaking, then our comments have been instrumental in causing those events to happen. The

instrumental function of communication is one of its most common purposes. We request a secretary to type three copies of a letter. We ask a friend at dinner to pass the butter, salt, etc. We order a salesman out of the house. Instrumental function of communication is loose enough to allow for several kinds of statements. There are statements that are clearly instrumental in their wording. If we say "*Shut the door*" and the door is then shut, we may assume that the noise we made was influential in the shutting of the door. There are also statements for which the result cannot be easily attributed to our utterances. If on a day planned for a picnic it is raining and so we sing, "*Rain, rain, go away*" - and the rain does stop it could be immodest to assume that our words caused that action. Much of prayer has been traditionally instrumental and if the faithful believe that some prayers have been answered we could say that for these people the prayer was an instrumental communication.

Some statements are instrumental in intent or effect, but are not phrased as such. For example, if you want the salt passed to you, you may request it directly (instrumental) or you comment that the food needs salt (transmitting information). If a wife wants a new fur coat, she may request it directly or she may comment on how well dressed her husband seems, especially when compared to her (apparently an effective technique). One instrumental request may result in a different instrumental action, as when commercial airlines do not ask passengers to stop smoking but to "observe the no smoking sign".

1.d. Affective function

Communication in which the message evokes emotional feelings of the speaker toward the listener is known as affective communication. Compliments, praise, flattery, snide and cutting remarks may be so classified. There are affective elements in many of the functions of communication. Phatic communication may contain praise as when old friends greet by saying, "*You are looking great!*" Instrumental purposes are often best served through effective communications too. It seems to be part of a woman's role in our society to use more affective communication than does the opposite sex. Where tradition has not given women authority in all situations women have had to achieve their goals indirectly. And this indirection may be reflected in instrumental desires disguised in affective language. The wife who says to her husband "*You look so handsome all dressed up*", might be requesting a new wardrobe for herself, or be asking to go out to dinner rather than just complimenting her husband. Affective language is also convincing language. In many cases a person would not do something if asked to do it directly; he would be aware of reasons that might not be able to accept. We seem to prefer to do things we think we want to do, not things we are told to do. To make another person feel good or bad through language is a rather common and vital function of communication. The non-affecting communication may be honest, fair, sincere. But to one who does not expect it the communication is cold and unfeeling.

1.e. Catharsis

When you are angry, disturbed, hurt physically or mentally, probably you give expression to your feelings. It is curious that expressions, which could be as personal as the feelings that evoke them are rather stylized and predictable within a language. Words like "ouch!" or "oh!" are spoken by people who speak English, whereas our neighbours who speak Spanish will say "ay!" when they express a comparable feeling. Grunts may be the only universal expression of catharsis. When pain or frustration is sufficient, our cathartic expression becomes more obviously symbolic. We move from the "ouch" to words that might be used in other ways, most often words that are socially disapproved of. We swear or curse or substitute words that sound something like the popular curses. We find that different kinds of expressions for releasing tension are appropriate among different ages and occupation. A sailor who is angry is not expected to say "Oh, goodness me!" and an angry nun is not expected to sound like a sailor. The physical stimulus finds expression in a symbol. This symbol eventually ceases to stand for directly anything in the outside world except an attitude towards whatever produced it. We move from physical sensation to verbal assault on that sensation ("damn it!") to mere release of tension. The idea of cursing dates to times when the belief in magic language was more common. There was a time when "God damn, you " was meant as a magic curse to bring about suffering. Expressions of catharsis have no referential meaning, and any word may serve the cathartic function. Probably each person has some favourite expressions for releasing anger. If you were to prepare a list of cathartic expressions, ranging them according to the degree of tension to be released, you might find it an easy task too which indicates that there are personal favourites for a choice of catharsis. The meaning of any of these expressions is to be found in what they do for us, not in a dictionary or in what they do for anybody else. Through repetition we give our select swear words added significance, so that with each new experience and repeated expression we may recall the release of tension from past experiences. If you have studied another language, you may have learnt the kinds of swear words that are most common in that language. In the literal translation they may not seem "to do much for you". Obviously, they cannot, for they have not yet come to be associated with the experiences that give them meaning. This same observation might be made for all words, but the language of catharsis, associated with the strongest of emotions is the most extreme example of the general principle.

1.f. Magic

The belief in the magic power of words exists in all cultures and takes the form of superstitions, instrumental curses. At the root of the attitude of magic is the assumption that words are part of the thing to which they refer and often, that words precede the thing (such as expressed in the Bible): "*In the beginning was the Word, and the Word was with God, and the Word was God. He was with God in the beginning.*" Another quality of the magic attitude of words is that "words stand for things". With this belief it follows that one can alter a thing by altering its word. If I

write your name on a piece of paper and burn it, you, too, will burn or at least suffer pain. Words in the magical interpretation must be treated with the same care as one would treat what the words stand for. A common example of the belief in word-magic is the hesitancy to speak of possible dangers. If, on an airplane, you remark about the possibility of crashing, fellow passengers may turn on you as if your utterance of the possibility might just cause that to happen. In some cases, of course, it may be simply that others do not wish to think of unpleasant things; but the manner and intensity of the reply often indicates a very real fear of the words. Symbols associated with persons have long been recognized for their magical associations. Personal names have been regarded as "part of the person", so that what is done to the name results in affecting the person. Elements of this attitude are still very common today, as when parents give their child the name of somebody important to them so that the child will be like his namesake. The magical attitude toward personal names requires that these not be taken in vain or, in some cases, not even uttered. Here the name is never a mere symbol, but is part of the personal property by its bearer; property which is exclusively reserved to him. The belief in the magic function of language is based on assumptions that are quite opposed to the discipline of semantics which regards words as conventional, convenient and without necessary associations with persons or objects in themselves. There is a sense, however, in which words do have "power". Words have the "power" to limit our thoughts, though this is a different sense of the word "power". With rumour, with labels that evoke signal reactions and with labels we try to live up to, we see some effects of "the power" of words. Such powers, however, are not magical, for they are not to be found in the words. Rather, the powers are social and thus they are effective only to the degree that we accept our language without evaluation and respond to words without evaluation. When we understand and evaluate our language habits/this social magic spell of words is broken.

1.g. Ritual function

The language of the rituals of secret organizations, social fraternities, lodges and some religious or political organizations is kept secret and is known only to their members. But the language of other rituals - patriotic, religious, academic and so on - is not kept private. Nevertheless, an oath of allegiance or a communal prayer can affect the nervous system as no statement of fact or judgement can. The three characteristics of most rituals are:

- 1) the rituals must be performed with others (immediately or symbolically);
- 2) they must be performed on some occasion;
- 3) they must be performed with special care to details.

Conventions of many kinds, political, social, and academic serve more of a ritual function than the function of exchanging information or achieving some instrumental goal. What is called a report may better serve as an incantation. No group can maintain itself without strong cohesiveness. But if the main result of the group's effort is only cohesiveness then surely we have the origins of a new ritual.

2. Functions of nonverbal communication

When communicating, nonverbal messages can fulfil 6 functions: *repeating, conflicting, complementing, substituting, regulating and accenting/moderating*.

Repeating: "Repeating" consists of using gestures to strengthen a verbal message, such as pointing to the object of discussion.

Conflicting: Verbal and nonverbal messages within the same interaction can sometimes send opposing or conflicting messages. A person verbally expressing a statement of truth while simultaneously fidgeting or avoiding eye contact may convey a mixed message to the receiver in the interaction. Conflicting messages may occur for a variety of reasons often stemming from feelings of uncertainty, ambivalence, or frustration. When mixed messages occur, nonverbal communication becomes the primary tool people use to attain additional information to clarify the situation; great attention is placed on bodily movements and positioning when people perceive mixed messages during interactions.

Complementing: Accurate interpretation of messages is made easier when nonverbal and verbal communication complement each other. Nonverbal cues can be used to elaborate on verbal messages to reinforce the information sent when trying to achieve communicative goals; messages have been shown to be remembered better when nonverbal signals affirm the verbal exchange.

Substituting: Nonverbal behavior is sometimes used as the sole channel for communication of a message. People learn to identify facial expressions, body movements, and body positioning as corresponding with specific feelings and intentions. Nonverbal signals can be used without verbal communication to convey messages; when nonverbal behavior does not effectively communicate a message verbal methods are used to enhance understanding.

Regulating: Nonverbal behavior also regulates our conversations. For example, touching someone's arm can signal that you want to talk next or interrupt.

Accenting/Moderating: Nonverbal signals are used to alter the interpretation of verbal messages. Touch, voice pitch, and gestures are some of the tools people use to accent or amplify the message that is sent; nonverbal behavior can also be used to moderate or tone down aspects of verbal messages as well. For example, a person who is verbally expressing anger may accent the verbal message by shaking a fist.

Communication is a complex dynamic system. It involves all modes of sending, receiving and feedback. It appears at a young age and decoding ability increases with age. At times nonverbal cues may be used to emphasize a message we are trying to convey. On other occasions it replaces verbal communication. Communication is used in everyday life, from greeting a stranger to touching a lover. The nonverbal behavior an individual uses is a product of characteristics

endowed at birth and socially learned norms. Knowledge of the effects nonverbal communications introduce is needed, because our awareness may enhance favorable communication. Nonverbal cues may be unconsciously acted and reacted upon, regulating proximity, gestures, eye gaze and touch. Each component of nonverbal behavior affects our relationship and interpersonal environment in intricate ways. Nonverbal cues provide insight into affect states, influence another's perception of an individual's competence, persuasiveness, power, sincerity and vulnerability. In a new age where increasing population is decreasing personal space, it is imperative to understand cultural and personal communication differences and similarities.

Self-check test

1. What is phatic communication?
2. Describe the rule applied to phatic communication.
3. What are three needs necessary to establish meaningful relationships?
4. What is instrumental communication?
5. What is affective communication?
6. Describe cathartic function of communication.
7. What is magic?
8. What is ritual?
9. Point to and describe 6 functions of non-verbal communication.

Recommended Readings

1. Andersen P. *Nonverbal Communication: Forms and Functions*. – Waveland Press, 2017.
2. Andersen P. *The Complete Idiot's Guide to Body Language*. – Alpha Publishing. – 2004.
3. Argyle M. *Bodily Communication*. – Madison: International Universities Press. – 2018.
4. Bull P. *Posture and Gesture*. – Oxford: Pergamon Press. – 1987.
5. Burgoon J, Guerrero L., Floyd K. *Nonverbal communication*. – Boston: Allyn & Bacon. – 2011.
6. Floyd K., Guerrero L. *Nonverbal communication in close relationships*. – Mahwah, New Jersey: Lawrence Erlbaum Associates. – 2006.
7. Hymes D. Introduction: Toward Ethnographies of Communication / J. J. Gumperez and D. Hymes. *The Ethnography of Communication*. Special issue of *The American Anthropologist*. – Part 2, 1964. – P. 1-29.
8. Gudykunst W., Ting-Toomey S. *Culture and Interpersonal Communication*. – California: Sage Publications Inc., 2008.
9. Hanna J. *To Dance Is Human: A Theory of Nonverbal Communication*. – Chicago: University of Chicago Press. – 1987.
10. Hargie O., Dickson D. *Skilled Interpersonal Communication: Research, Theory and Practice*. – Hove: Routledge. – 2004.
11. Knapp M., Hall J. *Nonverbal Communication in Human Interaction*. – Wadsworth: Thomas Learning. – 2017.

12. Ottenheimer H. The anthropology of language: an introduction to linguistic anthropology. – Kansas State: Thomson Wadsworth, 2007.
13. Reiland M. Nonverbal communication in everyday life. – Boston: Allyn & Bacon. – 2009.

Lecture 6

Forms of communication

Plan

1. *Dialogue. Structured dialogue.*
2. *Characteristics of the dialogue.*
3. *Monologue.*

1. *Dialogue. Structured dialogue*

The definition of the term “dialogue” in different linguistic encyclopedias is the following:

- a conversation between two persons;
- the lines spoken by characters in drama or fiction;
- a literary composition in the form of a conversation between two people; "he has read Plato's Dialogues in the original Greek";
- negotiation: a discussion intended to produce an agreement; "the buyout negotiation lasted several days"; "they disagreed but kept an open dialogue"; "talks between Israelis and Palestinians".

Dialogue (spelled *dialog* in American English) is a literary form consisting of a written or spoken conversational exchange between two or more people. Its chief historical origins as narrative, philosophical or didactic device are to be found in classical Greek and Indian literature, in particular in the ancient art of rhetoric. Having lost touch almost entirely in the 19th century with its underpinnings in rhetoric, the notion of dialogue emerged transformed in the work of cultural critics such as Mikhail Bakhtin and Paulo Freire, theologians such as Martin Buber. The Russian philosopher and semiotician Mikhail Bakhtin's theory of dialogue emphasized the power of discourse to increase understanding of multiple perspectives and create myriad possibilities. Bakhtin held that relationships and connections exist among all living beings, and that dialogue creates a new understanding of a situation that demands change. In his influential works, Bakhtin provided a linguistic methodology to define the dialogue, its nature and meaning: dialogic relations have a specific nature: they can be reduced neither to the purely logical (even if dialectical) nor to the purely linguistic (compositional-syntactic). They are possible only between complete utterances of various speaking subjects. Where there is no word and no language, there can be no dialogic relations; they cannot exist among objects or logical quantities (concepts, judgments, and so forth). Dialogic relations presuppose a language, but they do not reside within the system of language. They are impossible among elements of a language. Dialogue is a delicate process. Many obstacles inhibit dialogue and favor more confrontational communication forms such as discussion and debate. Common obstacles including fear, the display or exercise of power, mistrust, external influences, distractions, and poor communication conditions can all prevent dialogue from emerging.

Structured dialogue represents a class of dialogue practices developed as a means of orienting the dialogic discourse toward the problem of understanding and consensual action. Whereas most traditional dialogue practices are unstructured or semi-structured, such conversational modes have been observed as insufficient for the coordination of multiple perspectives in a problem area. A disciplined form of dialogue, where participants agree to follow a framework or facilitation, enables groups to address complex problems shared in common. Aleco Christakis (Structured Dialogic Design) and John N. Warfield (Science of Generic Design) were two of the leading developers of this school of dialogue, which was practiced for over 20 years. The rationale for engaging structured dialogue follows the observation that a rigorous bottom-up democratic form of dialogue must be structured to ensure that a sufficient variety of stakeholders represents the problem system of concern, and that their voices and contributions are equally balanced in the dialogic process. Today, structured dialogue is being employed by facilitated teams for peacemaking, global community development, government and social policy formulation, strategic management, health care, and other complex domains. In one deployment, structured dialogue is (according to a European Union definition) "a means of mutual communication between governments and administrations including EU institutions and young people. The aim is to get young people's contribution towards the formulation of policies relevant to young people's lives." The application of structured dialogue requires one to differentiate the meanings of discussion and deliberation.

2. *Characteristics of the dialogue*

Dialogue tends to develop in relationships, groups, and communities. It is characterized by the following features:

- *Immediacy of presence.* Presence implies that dialogue partners speak and listen from a common place or space from which they experience access to each other. Communicators sense that, for each other, they are relating *here* (a shared space) and *now* (an immediate moment in time). In many situations, the first task of communicators or planners is to clear such a space, but the clearing doesn't guarantee dialogue so much as it enables it.
- *Emergent unanticipated consequences.* Dialogue presumes a certain spontaneity and improvisation linking communicators. The reason dialogue often seems to repair manipulation is that, in it, all parties enter without full knowledge of the directions that may be taken within the conversation. They are willing to invite surprise, even at the expense of sacrificing strategy at times.
- *Recognition of strange otherness.* By strange otherness we mean that a dialogue partner assumes not only that the other person is different (that is often obvious, of course), but is different in strange—that is, in essentially and inevitably unfamiliar or unpredicted—ways. Strangeness means the other cannot be reduced to an adjusted version of a 'me'; there is always more, and confronting the strange implies imagining an alternate perspective. Such strangeness is not necessarily a threat, but is as often an invitation for learning.

- *Collaborative orientation.* By collaboration, we suggest that dialogue partners stand their own ground while they remain concerned about the current and future ground of others. Dialogic collaboration, however, does not suggest happy two-way backscratching. Indeed, collaboration embraces conflict, because by recognizing accurately the other's perhaps antithetical position in relation to one's own, we confirm each other.
- *Vulnerability.* Dialogue finds participants open to being changed. We speak from a ground that is important to us, but we do not defend that ground at all costs.
- *Mutual implication.* A process of dialogue means that speakers anticipate listeners or respondents and incorporate them into messages. In a dialogic process speaker and listener are interdependent, each constructing self, other, and their talk simultaneously. John Dewey and A.F. Bentley similarly used the word *transaction* to suggest a new sense of human causality. Humans aren't changed by actions traded back and forth from one individual to another, but by the very existence of relationship itself. Communication isn't primarily 'caused' by either party, but develops through the relation of both, in concert. "Even when one person might seem to be the sole speaker, the voices of listeners are already present", said Russian language theorist Mikhail Bakhtin. For the same reason, Martin Buber referred to the term *I-Thou* as a 'primary word' (not words, plural); what he called 'the between,' the relation, was a unified phenomenon.
- *Temporal flow.* Understanding dialogue always involves understanding the past out of which it flows and the future that it unfolds so persistently. As we have written elsewhere, it 'emerges from a past, fills the immediate present (and thus, is experienced as 'wide,' 'deep,' 'immersing,' or 'enveloping' by participants), and prefigures an open future'.
- *Genuineness and authenticity.* Dialogue partners base their relationship on the presumption of authentic or genuine experience. This means not that people always tell the truth, but that no sense of a genuine dialogue can be based on a participant's self-consciously untruthful, hidden, deceptive, or blatantly strategic set of interpersonal calculations. Rather, in dialogue, communicators are assumed to speak and act in ways that match their worlds of experience. "Where such trust breaks down, dialogic potential dissolves."

3. Monologue

A *monologue* (or *monolog*) is an extended speech by one person. The term has several closely related meanings (dramatic monologue, soliloquies, interior monologue etc.). *Dramatic monologue* is a poem written in the form of a speech of an individual character; it compresses into a single vivid scene a narrative sense of the speaker's history and psychological insight into his character. Though the form is chiefly associated with Robert Browning, who raised it to a highly sophisticated level in such poems as "My Last Duchess," "The Bishop Orders His Tomb at St. Praxed's Church," "Fra Lippo Lippi," and "Andrea del Sarto," it is actually much older. Many Old English poems are dramatic monologues—for instance, "The Wanderer" and "The Seafarer." The form is also common in folk ballads. *Soliloquy*

is a passage in a drama in which a character expresses his thoughts or feelings aloud while either alone upon the stage or with the other actors keeping silent. This device was long an accepted dramatic convention, especially in the theatre of the 16th, 17th, and 18th centuries. Long, ranting soliloquies were popular in the revenge tragedies of Elizabethan times, such as Thomas Kyd's *Spanish Tragedy*, and in the works of Christopher Marlowe, usually substituting the outpouring of one character's thoughts for normal dramatic writing. *Interior monologue*, in dramatic and nondramatic fiction is a narrative technique that exhibits the thoughts passing through the minds of the protagonists. These ideas may be either loosely related impressions approaching free association or more rationally structured sequences of thought and emotion. Interior monologues encompass several forms, including dramatized inner conflicts, self-analysis, imagined dialogue (as in T.S. Eliot's "The Love Song of J. Alfred Prufrock"), and rationalization.

Self-check test

1. Give definition of the term "dialogue".
2. What is a structured dialogue?
3. What are the characteristic features of the dialogue?
4. What is a monologue? Describe its forms.

Recommended Readings

1. Bakhtin M. *Speech Genres and Other Late Essays*. – Tx: University of Texas Press, 1986.– 238 p.
2. Maranhão T. *The Interpretation of Dialogue*. – Chicago: University of Chicago Press, 1990.
3. Cohn D. *Transparent Minds: Narrative Modes for Presenting Consciousness in Fiction*. – Chicago: University of Chicago Press, 1978.
4. Edwardes J. *The Faber Book of Monologues*. – Faber and Faber, 2005.
5. Hirsh J. *Shakespeare and the History of Soliloquies*. – Madison: Fairleigh Dickinson University Press, 2003.

Lecture 7

General characteristics of the components of communicative/speech act

Plan

1. *The essence of communicative act.*
2. *The functions of communicative act.*
3. *Pragmatic aspects of communication.*
 - 3.a. *Conversational maxims and implicatures.*
 - 3.b. *Meaning based on intention.*
 - 3.c. *Presupposition.*
 - 3.d. *Indexical Expressions.*
 - 3.e. *Metaphors.*
4. *Language competence.*
 - 4.a. *Grammatical competence.*
 - 4.b. *Discourse competence.*
 - 4.c. *Sociolinguistic competence.*
 - 4.d. *Strategic competence.*

1. The essence of communicative act

Language as a system of rules (including phonology, morphology, syntax, grammar, semantics, pragmatics and focusing on rules describing competence rather than performance) limits our ability to look at communication system more generally and to see important characteristics of speech forms that are used within speech communities and between them. Basic limitations of theoretical linguistics of the past to the sentence as the unit of analysis and to referential meaning as the only relevant sort of meaning, of interest for analysis primarily in terms of "same or different" can be overcome in part by taking a more inclusive view on speech as a form of communication; by starting with an analysis of the "communicative act" (or simply the "speech act") in terms of the components of which it is composed and the functions that can be served through it (see the scheme below).

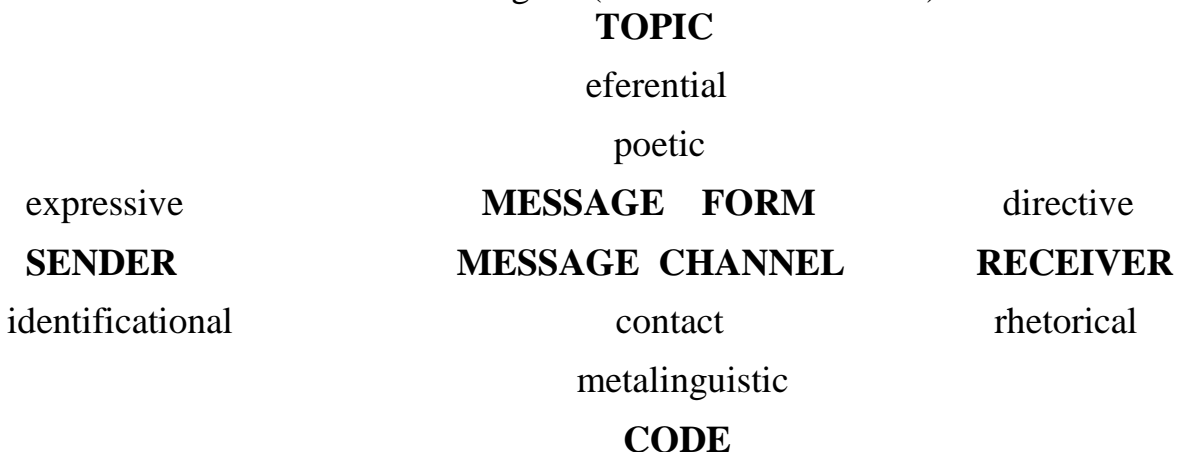

Communicative Act (or Speech Act) Components (according to Hymes and Jakobson).

The components and functions above are all within (or "enclosed by") another component, the **CONTEXT**, and an associated function of the communicative act as a whole could be called contextual. Different societies will make differential use of and definitions of these speech act components. The ethnographer (one who wants to describe a culture) would like to list all the possible named speech acts, all the possible senders, all the possible receivers, all the kinds of codes, all the named kinds of message form, all the message channels possible, all the named topics, etc.

2. *The functions of communicative act*

a. **connected with the sender (speaker)**

1. *Identificational* function of the communicative act is most closely associated with the sender – such things as voice set, accent, intonation, etc. tell the receiver about sender's age, sex, etc.; i. e. they identify him, and they are generally involuntary.

2. *Expressive function* (the choice of words, intonation, etc). expresses emotions and attitudes toward the receiver or other component of speech act.; generally under voluntary control.

b. message channel could be represented by gestures, whistling, drumming, speech and is realized through the contacts – physical – (sound hits the ears) and psychological – *phatic communion* (i.e. social contact).

c. message form is closely connected with *poetic function*. It is not limited to poetry, this function is expressed as manipulations of and restrictions on a message form, and these can be of many different sorts. Different amounts and varieties of aesthetic appreciation are derivable from various ways of formulating a message with any given referential content.

d. topic (what the message is about) is associated with *referential function*: it is closely tied to the dictionary meanings of messages.

e. code (signalling units of which a message is composed) realizes *metalinguistic function*, i.e. information about the code that is conveyed in a speech act.

f. receiver – connected with the *directive function* – concerns subsequent activity of the receiver as directed by what the speaker says. (e.g. "Would you close the door, please?") and a rhetorical function – concerns the receiver's outlook as it is affected by what is said, e.g. "What a nice dress."

g. setting (context) – (relevant features constituting a specific setting most often involve **participants, location, and time** of the speech act) is realized through the *contextual function* of the speech act. Setting component is reflected in messages saying something about the time, place, or persons in the interaction. Many linguistic forms referring to these things cannot be interpreted without reference to the speech act itself, for their meanings are not fixed but relative (e.g. 'me', 'you', 'here', 'there', 'now', 'then') (e.g. "It happened yesterday"; "Oh, there you are"). In some cases, the primary function of the whole speech act is contextual.

Once we are familiar with the *functions* of the speech act we can think of them in a slightly different way by calling these functions *meanings* that can be associated with the speech act. So in this sense there are at least 9 general kinds of meanings that can be associated with the communicative/speech act.

3. Pragmatic aspects of communication

The prominent mechanisms that enable conversationalists to communicate more or different information than is literally said include the following:

- conversational maxims and implicatures;
- presuppositions;
- indexical expressions;
- metaphor;

Communication itself, quite apart from mere speaking alone, often goes beyond the bounds of what is literally said. To account for the gap between what is said and what is communicated, several of the pragmatic theories that we will outline below make general appeals to the conventions and assumptions that trigger inferences, to intentions, or to shared knowledge and beliefs. All the theories are concerned with communication.

3.a. Conversational maxims and implicatures

Conversational maxims and implicatures are the foundation of H.P. Grice's pragmatic account of communication. To account for the distinction between what is directly said and what is conveyed by an utterance, Grice proposed that in conversing, participants proceed according to an implicit assumption that he terms the *cooperative principle*: "Make your conversational contribution such as is required, at the stage at which it occurs, by the accepted purpose or direction of the talk exchange in which you are engaged." Another set of assumptions, called conversational maxims, underlie the cooperative principle:

1. Quality: Try to make your contribution one that is true.

(1) Do not say what you believe to be false.

(2) Do not say that for which you lack adequate evidence.

2. Quantity

(1) Make your contribution as informative as is required for the current purposes of the exchange.

(2) Do not make your contribution more informative than is required.

3. Relation: Be relevant.

4. Manner: Be perspicuous.

(1) Avoid obscurity of expression.

- (2) *Avoid ambiguity.*
- (3) *Be brief (avoid unnecessary prolixity).*
- (4) *Be orderly.*

H. Grice demonstrates that conversational participants convey meanings beyond that which is said if they assume that the other is adhering to the cooperative principle and its maxims. Conversationalists can deal with the maxims in several ways: they can follow them, violate one of them, opt out of one of them, sacrifice one to the other if they clash, or flout them. Lying, for example, violates the maxim of quality. The maxims derive their explanatory power from what happens when behavior appears not to conform to them. Thus, as Green (1989) explains, since speakers assume that hearers adopt the cooperative principle and its maxims for interpreting speech behavior, the speaker is free to exploit it, and to speak in such a way that his behavior must be interpreted according to it. If the speaker's remark seems irrelevant, the hearer will attempt to construct a sequence of inferences that make it relevant or at least cooperative. This exploitation of the maxims is the basic mechanism by which utterances are used to convey more than they literally denote, and Grice called it implicature. Other scholars have refined Grice's approach. Sperber and Wilson, for instance, have reduced the Gricean framework to relevance. Time limitations prevent the summation of their views here.

3.b. Meaning based on intention

Before proceeding to presuppositions, it is worth noting that Grice also proposed a notion of meaning based on intention that further helps account for how different or more information can be communicated than is literally said. Grice describes his notion of intentional communication as non-natural meaning, or meanings, characterizing it as follows, with "S" standing for speaker, "H" for hearer, "uttering U" for the utterance of a linguistic token, and "z" for roughly some belief or volition invoked in H:

S meant_{mn} z by uttering U if and only if:

- (1) *S intended U to cause some effect z in recipient H*
- (2) *S intended (i) to be achieved simply by H recognizing the intention (i).*

The above characterization by Grice states, according to Levinson (1983), that communication consists in the speaker intending to cause the hearer to think or do something just by getting the hearer to recognize that the speaker is trying to cause that thought or action. Other issues and problems aside, Grice's theory can explain the difference between what is literally said and what is conveyed through intention. For example, "mathematics is fascinating" said ironically may be intended, despite its literal meaning, to communicate that "mathematics is rather boring" and to produce the effect that the speaker stops talking about mathematics.

3.c. Presupposition

Presupposition, which like conversational implicature is another kind of pragmatic inference, refers to propositions whose truth is taken for granted in the utterance of a linguistic expression. The presupposed propositions enable more to be conveyed than is literally said. Moreover, presuppositions may communicate more or different information from what is literally said because they involve not just a single implication but a "family of implications," which derives from the fact that the presupposition is background, as Chierchia and McConnell-Ginet point out. Several cases of presupposition have been distinguished. A few representative cases and brief illustrative examples follow. The *Existence of presupposition* in definite descriptions, the expressions like "The present king of France is bald," presupposes that there exists a king of France. *Factive presuppositions* are typically associated with expressions that take a sentential subject or object. Wh-questions and iterative participles are also often associated with presuppositions, as are the counterfactive verb *pretend* and the counterfactual conditional of *if-then constructions*. The connotations of certain lexical items may also reflect presuppositions. Such connotations enable more to be conveyed than is literally said because of the properties that language users attribute to the presumed intended referents of the words. A classic example of a connotation presupposition is "assassinate". Saying "John assassinated Kennedy" presupposes that the killing was intentional, that Kennedy had political power, and that removing Kennedy from that power was the motivation behind the killing.

3.d. Indexical expressions

Indexical expressions, including deictic reference, also play a role in accounting for how either more or different information is conveyed than literally said. In his classic 1954 paper, Bar-Hillel argued that indexicality is an inherent property of language and that many of the declarative sentences people utter are indexical in that they involve implicit references to the speaker, hearer, time or place of utterance, etc., or the use of demonstratives, time adverbs, and tenses. The reference of indexical expressions containing words like *I, me, you, here, then, now, this, etc.*, cannot be determined without taking into account the context of the utterance. Minimally, the context required for the interpretation of indexical expressions includes the time, place, speaker, and topic of the utterance.

3.e. Metaphors

Metaphors are another mechanism by which more can be communicated than literally said. Green (1989) maintains that metaphors like "Eric is a pig" and "that's a half-baked idea" are interpreted figuratively because the speaker and hearer both know that the literal interpretation of such utterances would be nonrational, a view that accounts for metaphorical uses of language under the cooperative principle and its maxims. Both hearer and speaker know that Eric cannot be a pig, so both assume

that Eric is somehow like a pig. "Thus the referring functions inferred in the interpretation of metaphors involve the referring function 'like x'".

4. *Language competence*

Linguistic competence defines the system of rules that governs an individual's tacit understanding of what is acceptable and what is not in the language they speak. The concept, introduced by the linguist Noam Chomsky in 1965, was intended to address certain assumptions about language, especially in structuralist linguistics, where the idea of an unconscious system had been extensively elaborated and schematized. Competence can be regarded as a revision of the idea of the language system. The empirical and formal realization of *competence* would be *performance*, which thus corresponds to diverse structuralist notions of *parole*, *utterance*, *event*, *process*, etc. N. Chomsky argues that the unconscious system of linguistic relations, which Ferdinand de Saussure named *langue*, is often mistakenly associated with *knowledge* or *ability* (or know-how). N. Chomsky is concerned to establish a science that would study what he calls "the language faculty", in analogy with other mental faculties like logic, which as a kind of intuitive reasoning power requires no accumulation of facts or skills in order to develop. Grammatical knowledge too seems to be present and fully functional in speakers fluent in any language. So, competence in Chomsky's sense implies neither an accumulated store of knowledge nor an ability or skill. He rejects Saussure's *langue* as "merely a systematic inventory of items", and instead returns to a rationalist model of underlying competence regarded as "a system of generative processes". This has the advantage of explaining plausibly events of linguistic innovation in unpredictable situations, as well as pertinence of expression and understanding in particular contexts. This faculty seems to be absent in animals and (so far) in machines that can nonetheless be taught or programmed to use signs in imitative or predetermined ways. A key source for Chomsky's conception is Rene Descartes, whose concern with the creative powers of the mind leads him to regard human language as an instrument of thought. N. Chomsky also cites Wilhelm von Humboldt as a source for the conception of the generative nature of competence. Humboldt argues that use of language is based upon the demands that thinking imposes on language, and that this is where the general laws governing language originate. In order to understand the instrument or the faculty itself, however, it would not be necessary or even desirable to consider the creative abilities of great writers or the cultural wealth of nations; the linguist would, rather, attempt to abstract the generative rules, which remain unchanged from individual to individual. Competence, in Chomsky's sense, is to be regarded as entirely independent of any considerations of performance, which might concern other disciplines, like pragmatics, psychology, medicine, or literary theory.

One of the best known models of language ability is known as *communicative competence*. This model was developed to account for the kinds of knowledge people need in order to use language in meaningful interaction. The term was originally coined by anthropologist Dell Hymes as a means of describing the knowledge language users need in addition to the grammatical forms of the

language. The term was then adopted by the language teaching community after it had been developed into a model for that field by Michael Canale and Merrill Swain, then by Sandra Savignon. In the version commonly used by language teachers, the model includes four components: grammatical competence, discourse competence, sociolinguistic competence and strategic competence.

4.a. Grammatical competence

Grammatical competence is the ability to use the forms of the language (sounds, words, and sentence structure). Most scholars agree that there is some kind of fundamental difference between being able to use the forms of the language and being able to talk about the forms of the language.

4.b. Discourse competence

Discourse competence is the ability to understand and create forms of the language that are longer than sentences, such as stories, conversations, or business letters. Discourse competence includes understanding how particular instances of language use are internally constructed. For example, consider the following text: *The Space Cadets ate the rocketship. It was delicious!*

What is the meaning of the word "it" in this text? One can figure out that "it" refers to the rocketship previously mentioned because you have discourse competence in English that allows you to identify the referents of pronouns. Discourse competence also includes understanding how texts relate to the context or situation in which they are used. Let us consider the following text: *The party was a blast! After Melvin opened his presents and everyone played with his new Star Wars light saber, it was time to eat. Melvin blew out the candles and the Space Cadets ate the rocketship. It was delicious! Served with real astronaut ice cream. Melvin's parents really knocked themselves out this time.* Now can you see how the sentence "The Space Cadets ate the rocketship." could be correct? What else do you have to know in order to understand this text? Who is writing? How old are the people described? What kind of event is described? You can interpret the sentence because you perceive its coherence in the context of American cultural practices for children's birthday celebrations. What makes a text coherent often has less to do with sentence structure than with text structure and knowledge of the world.

4.c. Sociolinguistic competence

Sociolinguistic competence is the ability to use language appropriately in different contexts. Sociolinguistic competence overlaps significantly with discourse competence because it has to do with expressing, interpreting and negotiating meaning according to culturally-derived norms and expectations. Sociolinguistic competence is most obvious to us when the conventions governing language use are somehow violated, as for example when a child innocently uses a "bad" word or when the expectations present in one culture are unsuccessfully translated for another. It is our sociolinguistic competence that allows us to be polite according to

the situation we are in and to be able to infer the intentions of others. In our everyday life we vary the kind of language we use according to the levels of formality and familiarity. We express solidarity in groups to which we belong or wish to belong, for example in classroom chat with other students, or at a party. In situations where we may eventually have solidarity with the others present, but do not yet know them well, we express deference, for example at an international meeting of scholars in the same field. In situations where there is an obvious status difference between participants, we are careful to express the right amount of respect.

4.d. Strategic competence

Strategic competence is the ability to compensate for lack of ability in any of the other areas. What do you do when you don't know a word that you need? How do you manage a social situation when you aren't quite sure about the rules of etiquette? In both cases, you rely on your strategic competence to help you communicate. Everyone has some degree of strategic competence in any language. If you are hungry, but cannot speak the language, you can probably still make your need known through gesture and facial expression because hunger is a universal fact of human life. Language learners who really need to communicate in their adopted language tend to develop a number of strategies for making themselves clear in spite of their incomplete knowledge.

Let us suppose that you are visiting Hungary and suddenly realize that you need to buy some dental floss. You speak some elementary Hungarian but you don't know how to say "dental floss." Having located a likely place to make your purchase, you approach the clerk. Now what?

You can use gesture to convey your message. You can coin a word, perhaps "teethstring." You can use circumlocution: "I would like to buy thing for cleaning mouth parts. Inside. Please." If you can't get your message across, you can give up! Maybe your need for dental floss was not so urgent after all.

Self-check test

1. What are the components of communicative act?
2. Point to and describe the functions of communicative act.
3. What do pragmatic aspects of communication include?
4. What is language competence?
5. Describe the components of language competence.

Recommended Readings

1. Austin J. *How to do Things with Words.*— Oxford: Oxford University Press, 1975.
2. Bar-Hillel J. *Indexical Expressions / Mind / Vol. 63, 2004.* — P. 359–379.
3. Chomsky N. *Aspects of the Theory of Syntax.*— Cambridge: MIT Press, 1965.

4. Culler J. *On Deconstruction: Theory and Criticism after Structuralism*. – London: Routledge, 2003.
5. Hymes D. *The Ethnography of Speaking*. / In Gladwin T. & Sturtevant W.C. *Anthropology and Human Behavior*, 1962. – P. 13–53.
6. Hymes D. *Two types of linguistic relativity*. / In W. Bright *Sociolinguistics*. – The Hague: Mouton, 1966. P. 114-158.
7. Hymes D. *On communicative competence*. – Philadelphia: University of Pennsylvania Press, 1971.
8. MacCabe C. *Competence and Performance: the Body and Language in Finnegans Wake*. – London: Palgrave Macmillan, 2013.
9. Levinson S. *Pragmatics*. – Cambridge, England: Cambridge University. 1983.
10. Savignon S. *Communicative Competence: Theory and Classroom Practice*. – New York: McGraw-Hill. 2nd edition, 1997.
11. Sperber D., Wilson D. *Relevance: Communication and Cognition*. – Basil Blackwell, 1986.

Lecture 8

Components of communicative act connected with the language code

Discourse and discourse analysis

1. *Preliminary remarks*
2. *Defining discourse*
3. *Discourse and social practice*
4. *Discourse. Conversation as a discourse type*
 - 4.a. *Exchanges*
 - 4.b. *Conversational success*
5. *Maxims of communication*

1. *Preliminary remarks*

One of the approaches that has developed in analysing the way sentences work in a sequence to produce coherent stretches of speech is *discourse analysis*. It focuses on the structure of naturally occurring spoken language, as found in such "discourses" as conversations, interviews, commentaries and speeches. Traditionally this was the goal of rhetoric, and later of stylistics. The term "discourse analysis" was used in 1952 by Z.Harris who tried to spread distributional method from a sentence to coherent text and attract a sociocultural situation to its description.

Expanding language analysis beyond the level of the individual utterance originated from sociology, particularly from the "conversational analysis" initiated by H. Sacks (1935-1975) in the 1960s within the more general paradigm of ethnomethodology founded by H. Garfinkel. This work established bonds with the "Ethnology of speaking" approach founded by Dell H.Hymes, who had been trained in the anthropological tradition. What is more, both *conversational analysis* and the *Ethnography of Communication* found common grounds with Halliday and the London School, as well as with Prague school of linguistics. John J. Gumperz is generally credited with having drawn these various trends together in the later 1960s into the field known as "*discourse analysis*".

E.Benveniste was one of the first to give the word "discourse" (which in French linguistic tradition meant speech in general, text), a terminological meaning, having designated with it "*speech assumed by the speaker*" (e.g. various genres of oral communication, letters, memoirs and others). He contrasted discourse with an objective narration. Discourse differs from an objective narration with a number of grammatical features (tense system, pronouns etc.) and communicative purposes. Discourse analysis, being a relative social phenomenon solely depends on the wide range of disciplines, such as sociology, anthropology, cognitive and social psychology, philosophy, for knowledge and methodologies and it is difficult to draw a clear line of demarcation between certain linguistic fields, such as anthropological linguistics, psycholinguistic, discourse analysis and cognitive linguistics, as the approaches to "study of language in use" are borrowed

from these subfields and most of the times the findings are independently supported by the fresh evidences. Discourse analysis, in turn, is composed of a wide range of subdisciplines, such as pragmatics, conversational analysis, speech act theory and ethnography of speaking. The discipline studies language used in the context, so its subject matter is language as a whole, either written or spoken, in terms of transcriptions, larger texts, audio or video recordings, which provides an opportunity to the analyst to work with language rather than a single sentence.

2. *Defining discourse*

Discourse (from Latin *discursus* – argument, French speech) is verbal communication; talk, conversation, a formal treatment of a subject in speech or writing, such as a sermon or dissertation, a unit of text used by linguists for the analysis of linguistic phenomena that range over more than one sentence. A discourse may be:

- a coherent text in combination with extralinguistic (pragmatic, sociocultural, psychological) and other factors;
- text taken in an eventful aspect;
- speech viewed as a purposeful social action;
- a component, participating in the interaction of people and device of their consciousness (cognitive processes).

Discourse is speech "absorbed in life" (N.Arutyunova). Therefore the term "discourse" unlike the term "text" is not applied to ancient and other texts, connections of which with a living reality are not directly re-established. Discourse includes a paralinguistic accompaniment of speech (facial expression, gestures) performing the following basic functions, dictated by the discourse structure:

- **rhythmic** ("autoconducting");
- **referential**, connecting words with a subject area of language application (deictic gestures);
- **semantic** (compare facial expression and gestures, accompanying some meanings);
- **emotionally evaluative function** of influence on interlocutor, that is an illocutionary force (compare gestures, motives, beliefs).

Discourse is studied together with corresponding "forms of life" (compare reporting, interview, an examination dialogue, instruction, polite conversation, confession and others). With one of its sides discourse is turned to the pragmatic situation which is drawn for the coherence of discourse, its communicative adequacy, for clearing up its implications and presuppositions, for its interpretation. Vital context of discourse is modeled in the form of *frames* (typical situations) or *scenarios* (stressing the situation development). Elaboration of frames and scenarios is an important part of discourse theory. With its other side discourse is turned to mental processes of communication participants: ethnographical, psychological sociocultural rules and strategies of speech generation and perception in certain conditions (discourse processing), defining a necessary speed of speech, the degree of

its coherence, the correlation of general and concrete, new and known, subjective (non-trivial) and generally accepted, explicit and implicit in discourse content, the degree of its spontaneity, the choice of means for achieving a necessary object, fixation of a speaker's point of view etc.

In the broad sense the term "discourse" is used for designating various types of speech and speech compositions (e.g. prescriptive, practical, oratorical discourse), the coherence and purport of which is re-established taking into account the whole complex of strictly speaking non-language factors. Discourse, according to Zellig Harris, is a sequence of the utterances. He observes that: "Stretches longer than one utterance are not usually considered in current descriptive linguistics, the linguist usually considers the interrelations of elements only within one utterance at a time. This yields a possible description of the material, since the interrelations of elements within each utterance (or utterance type) are worked out, and any longer discourse is describable as succession of utterances, i.e. a succession of elements having the stated interrelations. This restriction means that nothing is generally said about the interrelations among whole utterances within a sequence." Grenoble (2000), explaining Harris's definition of discourse, states that: "Harris interestingly enough ruled out the kind of study, which discourse analysis aims to do. He is of the view that linguistic research focuses on the elements within an utterance; discourse can be considered as a sequence of utterance. Harris argues that the study of the interrelations between utterances within a discourse, the scope of a discourse analysis required much more information than the theoretical apparatus of that time could handle. While this held true for 1950s and 1960s, roughly, but 1970s saw an emerging body of different approaches including pragmatics, conversation analysis, textual linguistics, and relevance theory." Pragmatics as a general term, according to Grenoble (2000), can be understood in at least as many ways as discourse analysis; some linguists equate the two terms. In its narrow sense, it refers to linguistic theory that has been directly influenced by the philosophy of language. The search for larger linguistic units and structures has been pursued by scholars from many disciplines. Linguists investigate sentences when they are used in sequence. Ethnographers and sociologists study the structure of social interaction, especially as manifested in the way people enter into dialogue. Anthropologists analyze the structure of myths and folktales. Psychologists carry out experiments on the mental processes underlying comprehension. And further contributions have come from those concerned with artificial intelligence, Rhetoric, Philosophy and Style.

These approaches have a common concern: they stress the need to see language as a dynamic, social, interactive phenomenon – whether between speaker and listener, or writer and reader. It is argued that meaning is conveyed not by single sentences but by more complex exchanges, in which the participants' beliefs and expectations, the knowledge they share about each other and about the world, and the situation in which they interact, play a crucial part.

3. *Discourse and social practice*

The discourse view of language may also be defined as "language is a form of social practice". It means:

Firstly, language is a part of society, and not somehow external to it.

Secondly, language is a social process.

Thirdly, language is a socially conditioned process by other (non-linguistic) parts of society.

As language is a part of society there is an internal and dialectical relationship between language and society. Linguistic phenomena are social phenomena of a special sort, and social phenomena are (in part) linguistic phenomena. Linguistic phenomena are social in the sense that whenever people speak, listen, write or read, they do so in ways which are determined socially and have social effects. Even when people are most conscious of their own individuality and think themselves to be most cut off from social influences - "in the bosom of the family", for example – they still use language in ways which are subject to social convention. And the ways in which people use language in their most intimate and private encounters are not only socially determined by the social relationships of the family, they also have social effects in the sense of helping to maintain (or, indeed, change) those relationships.

Social phenomena are linguistic on the other hand, in the sense that the language activity which goes on in social contexts (as all language activity does) is not merely a reflection or expression of social processes and practice, it is a part of those processes and practices. E.g., disputes about the meaning of political expressions are a constant and familiar aspect of politics. People sometimes explicitly argue about the meanings of words like *democracy*, *nationalization*, *socialism*, or *terrorism*. More often, they use the words in more or less pointedly different and incompatible ways – examples are easy to find in exchanges between leaders of political parties. Such disputes are sometimes seen as merely preliminaries to or outgrowths from the real processes and practices of politics. Politics partly consists in the disputes and struggles which occur in language and over language. But it is not a matter of a symmetrical relationship "between" language and society as equal facets of a single whole. The whole is society, and language is one part of the social. And whereas all linguistic phenomena are social, not all social phenomena are linguistic – though even those that are not just linguistic (economic production, for instance) typically have a substantial, and often underestimated, language element.

Discourse, then, involves social conditions which can be specified as social conditions of *production* and *social conditions of interpretation*. These social conditions, moreover, relate to three different "levels" of social organization:

1) the level of the social situation, or the immediate social environment in which the discourse occurs;

2) the level of the social institution which constitutes a wider matrix for the discourse;

3) the level of the society as a whole.

So, in seeing language as discourse and a social practice, one is committing oneself not just to analysing texts, processes of production and interpretation, but to analysing the relationship between texts, processes and their social conditions.

4. Conversation as a discourse type

Of the many types of communicative act, most study has been devoted to conversation seen as the most fundamental and pervasive means of conducting human affairs. These very characteristics, however, complicate any investigation. Because people interact linguistically in such a wide range of social situations, on such a variety of topics, and with such an unpredictable set of participants, it has proved very difficult to determine the extent to which conversational behaviour is systematic, and to generalize about it. There is now no doubt that such a system exists. Conversation turns out, upon analysis, to be a highly structured activity, in which people tacitly operate with a set of basic conversational rules. A comparison has even been drawn with games such as chess: conversations, it seems, can be thought of as having an opening, a middle and an end game. The participants make their moves and often seem to follow certain rules as the dialogue proceeds. But the analogy ends there. A successful conversation is not a game: it is no more than a mutually satisfying linguistic exchange. Conversation as a discourse type may acquire different roles. The term conversation is widely used in a non-technical sense, and people seem capable of distinguishing it from other kinds of talk. They mean that the talk is less formal. Discourse analysts are rather vague about what they mean by *conversation* too, and some seem to use the term to describe any kind of oral interaction. It is possible to define the term as follows:

1. *It is not primarily necessitated by a practical task.*
2. *Any unequal power of participants is partially suspended.*
3. *The number of participants is small.*
4. *Turns are quite short.*
5. *Talk is primarily for the participants and not for an outside audience.*

These definitions are imprecise. For example, considering (3), there is no fixed number of participants at which conversation becomes impossible, but although a conversation can take place between five people, it cannot take place between a hundred. Or again, considering (4), there is no fixed length for turns in conversation, and sometimes one participant holds the floor for some time; yet although we might call a turn of four minutes part of a conversation, we would consider conversation to have ceased if someone talked for an hour and a half. Nevertheless, the definitions are useful despite their imprecision. The boundary between conversation and other discourse types is a fuzzy one, and there are many intermediate cases. A seminar, for example, might come somewhere between the two poles. We can represent the difference between the two as a cline, or continuum, with extreme cases at either end and a range of intermediate possibilities in between:

Formal spoken discourse _____ Conversation.

Talk at the conversation end of the cline is difficult to mould to any overall structure. Indeed it might seem initially that a part of the definition of conversation might be its unpredictability and lack of structure.

4.a. Exchanges

Because conversational discourse varies so much in length and complexity, analysis generally begins by breaking an interaction down into the smallest possible units, then examining the way these units are used in sequences. The units have been called "exchanges" or "interchanges", and in their minimal form consist simply of an initiating utterance (I) followed by a response utterance (R), as in:

I: What's the time?

R: Two o'clock.

Two-part exchanges (sometimes called "adjacency pairs") are commonplace, being used in such contexts as questioning/answering, informing/acknowledging, and complaining/excusing. Three-part exchanges are also important, where the response is followed by an element of feedback (F). Such reactions are especially found in teaching situations:

Teacher: Where were the arrows kept? (I)

Pupil: In a special kind of box (R)

Teacher: Yes, that's right, in a box (F)

What is of particular interest is to work out the constraints that apply to sentences of this kind. The teacher-feedback sequence would be inappropriate in many everyday situations:

A: Did you have a good journey?

B: Apart from a jam at Northhampton.

A: Yes, that's right, a jam at Northhampton.

Unacceptable sequences are easy to invent:

A: Where do you keep the jam?

B: It's raining again.

On the other hand, with ingenuity it is often possible to imagine situations where such a sequence could occur (e.g. if B were staring out of the window at the time). And discourse analysts are always on the lookout for unexpected, but perfectly acceptable, sequences in context, such as:

A: Good-bye.

B: Hello.

(used, for example, as A is leaving an office, passing B on the way in). Many jokes, too, break discourse rules as the source of their effect:

A: Yes, I can.

B: Can you see into the future?

4.b. Conversational success

For a conversation to be successful in most social contexts, the participants need to feel they are contributing something to it and are getting something out of it. For this to happen, certain conditions must apply. Everyone must have an opportunity to speak: no one should be monopolizing or constantly interrupting. The participants need to make their roles clear, especially if there are several possibilities (e.g. "Speaking as a mother linguist/student..."). They need to have a sense of when to speak or stay silent; when to proffer information or hold it back; when to stay aloof or become involved. They need to develop a mutual tolerance, to allow for speaker unclarity and listener inattention; perfect expression and comprehension are rare, and the success of a dialogue largely depends on people recognizing their communicative weakness, through the use of rephrasing (e.g. "Let me put that another way") and classification (e.g. "Are you with me?").

There, is a great deal of ritual in conversation, especially at the beginning and end, and when topics change. E.g., people cannot simply leave a conversation at any random point, unless they wish to be considered socially inept or ill-mannered. They have to choose their point of departure (such as the moment when a topic changes) or construct a special reason for leaving: routines for concluding a conversation are particularly complex, and cooperation is crucial if it is not to end abruptly, or in an embarrassed silence. The parties may prepare for their departure a long way in advance, such as by looking at their watches or giving a verbal early warning. A widespread convention is for visitors to say they must leave some time before they actually intend to depart, and for the host to ignore the remark. The second mention then permits both parties to act.

The topic of the conversation is also an important variable. In general it should be one with which everyone feels at ease: "safe" topics between strangers in English situations usually include the weather, pets, children and the local contexts (e.g. while waiting in a room or queue), "unsafe" topics include religious and political beliefs and problems of health. There are some arbitrary divisions: asking what someone does for a living is generally safe: asking how much they earn is not. Cultural variations can cause problems: commenting about the cost of the furniture or the taste of a meal may be acceptable in one society but not in another.

When two people with different social background meet, there is a tendency for their speech to alter, so that they become more alike – a process known as *accomodation or convergence*. Modifications have been observed in several areas of language, including grammar, vocabulary, pronunciation, speech rate, use of pause, and utterance length. Everyday examples are the slower and simpler speech used in talking to foreigners or young children; the way technical information is presented in a less complex manner to those who lack the appropriate background; the rapid development of catch phrases within a social group; and the way many people cannot stop themselves unconsciously picking up the accent of the person they are talking to. The process has even been observed with babies talking to adults: at 12 months they were babbling at a lower pitch in the presence of their fathers, and at a higher pitch with their mothers. *Speech divergence* also takes place when people

wish to emphasize their personal, social, religious, or other identity. There may be quite elementary reasons for the divergence, such as a dislike of the learner's appearance or behaviour; or there may be more deep-rooted reasons, such as the deliberate use of a minority language or ethnically distinctive accent or dialect.

The kind of activity in which we engage will directly influence the way we communicate. At one level, our activities reflect the social status we have and the roles we perform. But status and role are very general notions, within which it is possible to recognize a much more specific notion of "activity type". For example, priests have a well-defined status and role within a community; but while exercising their role as priests, they engage in a wide range of activities, such as leading a service, giving a sermon, exorcizing spirits, hearing confession, baptizing and visiting the sick. Many other occupations involve a similar variety; and in all cases there are linguistic consequences of the shift from one activity to another. Linguistically distinct activities are often referred to as *genres or registers*, though these terms are sometimes used to refer to all the contextually influenced varieties.

Activity influence is not restricted to occupational environments. We also engage in many kinds of activity in everyday speech and writing, such as gossiping, discussing, quarrelling, petitioning, visiting, telephoning, and writing our lists. Here too there are linguistic norms and conventions, although they are usually more flexible, and the genres are not always as easy to define as those associated with more formal activities. Similarly, a single person is the usual receiver, or addressee of a message, but here too we must allow for variations. We may address someone directly, or through an intermediary, such as a secretary, interpreter, or spokesperson. A third party may overhear what we are saying, or see what we have written, and we may consider this desirable or undesirable. And speech addressed to a group of people is common enough in everyday conversation, as well as in more formal contexts, such as sermons, toasts, and lectures, and the whole range of circumstances that define the world of spoken and written mass communication.

All of these contexts can influence the language used by the speaker. For example, to know that one is being overheard by one's superior can lead to marked alterations in speech, even to the extent of adopting a completely different stylistic level. One may need to defer to the broader audience by altering pronoun forms and using various politeness strategies, as well as by modifying non-linguistic behaviour (such as body movements and eye contact).

It is difficult to generalize about what is normal, polite, or antisocial in conversational practise, as there is so much cultural variation. Silence, for example, varies in status. It is an embarrassment in English conversations, unless there are special reasons (such as in moments of grief). However, in some cultures (e.g. Lapps, Danes, the Western Apache) it is quite normal for participants to become silent. Often who speaks, and how much is spoken, depends on a social status of the participants – for example, those of lower rank may be expected to stay silent if their seniors wish to speak.

5. *Maxims of communication*

The success of a conversation depends not only on what speakers say but on their whole approach to the interaction. People adopt a "cooperative principle" when they communicate: they try to get along with each other by following certain conversational "maxims" that underlie the efficient use of language. Four basic maxims have been proposed by H.P. Grice:

1. The maxim of quality states that speaker's contributions to a "conversation ought to be true. They should not say what they believe to be false, nor should they say anything for which they lack adequate evidence.

2. The maxim of quantity states that speakers' contributions should be as informative as is required for the purposes of the conversation. One should say neither too little nor too much.

3. The maxim of relevance states that contributions should clearly relate to the purpose of the exchange.

4. The maxim of manner states that the contribution should be orderly and brief, avoiding obscurity and ambiguity.

Other maxims have also been proposed, such as "Be polite", "Behave consistently". The principle of relevance has recently attracted most attention as it has been proposed as a fundamental explanatory principle for a theory of human communication.

Listeners will normally assume that speakers are following these criteria. Speakers may, of course, break (or "flout") these maxims – e.g. they may lie, be sarcastic, try to be different, or clever, but conversation proceeds on the assumption that they are not doing so. Listeners may then draw inferences from what speakers have said (the literal meaning of the utterance) concerning what they have not said (the implications, or "implicatures" of the utterance).

E.g. A: I need a drink. B: Try the bell.

If B is adhering to the cooperative principle, several implicatures arise out of this dialogue: for example, *The Bell* must be a place that sells drinks; it must be open (as far as B knows); it must be nearby. If B is not being cooperative (e.g. if he knows that *The Bell* is closed, or is the name of a greengrocer's), he is flouting the maxims of quality and relevance. Deliberate flouting of this kind is uncommon, of course, and occurs in such special cases as sarcasm, joking or deliberate unpleasantness. More likely is the inadvertent flouting of conversational maxims – as would happen if B genuinely did not know that *the Bell* was closed, and accidentally sent A on a wild goose chase. In everyday conversation misunderstandings often take place as speakers make assumptions about what their listeners know, or need to know, that turn out to be wrong. At such points the conversation can break down and may need to be "repaired", with the participants questioning, clarifying, and cross-checking. The repairs are quickly made in the following extract, through the use of such pointers as "I told you" and "sorry".

A: Got the time? B: No, I told you, I lost my watch. A: Oh, sorry, I forgot.

But it is quite common for participants not to realize that there has been a breakdown and to continue conversing at cross purposes.

Everyday conversation is so habitual that it is easy to forget its status as a genre, with its own norms and conventions, often very different from those used in written speech.

Self-check test

1. What is discourse analysis?
2. Z.Harris used the term (what term was used)?
3. What was initiated by Harvey Sacks?
4. Define discourse.
5. Describe the connection between discourse and social practice.
6. What is conversation?
7. What is exchange in conversation?
8. What is convergence or accomodation?
9. What are the requirements for successful conversation?
10. Describe 4 maxims of communication.

Recommended Readings

1. Harris Z. Discourse Analysis Reprints. – Mouton: 1St Edition edition, 1963. – 73 p.
2. Howarth D. Discourse (Concepts in the Social Sciences). – Open University Press, 2000. – 176 p.
3. Hymes D. Language in Culture and Society: A Reader in Linguistics and Anthropology. – HarperCollins, 2007.
4. Garfinkel H. Studies in Ethnomethodology. – Polity, 1991. – 304 p.
5. Gee J. An Introduction to Discourse Analysis: Theory and Method. – Routledge, 2010.– 224 p.
6. Gee J. Social Linguistics and Literacies: Ideology in Discourses. – Routledge, 2011. – 248 p.
7. Grenoble L. Endangered Languages: Language Loss and Community Response. – Cambridge University Press, 2009. – 320 p.
8. Gumperz J. Discourse Strategies (Studies in Interactional Sociolinguistics). – Cambridge University Press, 1982. – 240 p.
9. Mills S. Discourse. (The New Critical Idiom). – Routledge, 2004. – 176 p.
- 10.Sacks H. Social Science and Conversation Analysis. – Oxford University Press, USA, 1998. – 232 p.
- 11.Scollon R., Scollon S. Intercultural Communication: A Discourse Approach. Cambridge, MA: Blackwell, 2015.

Lecture 9

Text as a result and unit of communication

Plan

1. *Text as an object of analysis.*
2. *Text typology.*
 - 2.a. *Functional classification.*
 - 2.b. *Situational classification.*
 - 2.c. *Strategic classification.*
3. *Text and discourse.*
 - 3.a. *The nature of text*
 - 3.b. *The nature of discourse*

1. *Text as an object of analysis*

Linguistic discipline which analyzes the linguistic regularities and constitutive features of texts is called *text linguistics*. It has developed since the 1960s from its structuralist foundations (tagmemics, text analysis, the Prague School) and has been integrated into the research foundations of stylistics and rhetoric. The historical significance of text linguistics lies in the fact that it overcame the narrow sentence-specific perspective of linguistics and thereby created a basis for the interdisciplinary study of texts. The development of the discipline is reflected in the various definitions of text. If one defines 'text' as a sequence of sentences and thereby a unit of the linguistic system, text linguistics is an expanded sentence grammar and therefore constitutes *discourse grammar*. The methods of sentence analysis are transferred to transphrastic analysis and lead to the composition of text grammatical rules of cohesion. If one understands 'text' as a communicative unit, further features like *text function* or *text theme* result from text-grammatical regularities. In this broader framework, which includes text grammar, text linguistics includes the following problems: (a) general aspects of structural and functional text constituents, i.e. *textuality*; (b) classification of texts in the framework of a *text typology*; (c) problems concerning the integration of stylistics and rhetoric; (d) interdisciplinary-oriented research in the direction of text reworking and comprehensibility.

2. *Text typology*

Text typology is concerned with the identification of the criteria leading to the classification (typology) of texts (or text types, text classes, styles, genres). Depending on the criteria adopted, there are several possibilities of classifying the texts. Using some of the most obvious criteria, texts can be classified as spoken or written, dialogical or monological, spontaneous (unprepared) or ritual (prepared), informal or formal, individual (personal) and interindividual (interpersonal), private or public (official, institutional), subjective or objective, interactional (contact-oriented) and transactional (message-oriented), etc. However, all text types

identified on the basis of a single criterion, in contrast with those based on several criteria (*simplex* vs. *complex* styles, K. Hausenblas 1972; *secondary* vs. *primary* styles, Mistrík 1997), often include instances which may reveal a more complicated patterning of features than those suggested by these dichotomies; for example, news bulletin scripts read by newscasters, dictation of a letter to a secretary, ritualized exchanges (greetings, politeness formulae) characterizing conversations, interactional features contained in otherwise transactional encounters (lectures). Dolník and Bajzíkova (1998) maintain that it is possible to approach texts as either theoretical linguistic constructs (text typology), or as concrete “psychological realities” (text classification). The latter approach is based on the intuition possessed by every language user which is acquired through his/her practical experience with the production of texts and which represents a component of his/her communicative (stylistic) competence. The authors have it that one of the most important criteria is based on the study of the ways that dominating communicative functions of texts determine the choice of expressive means of language; e.g., in appeals, warnings, public notices the conative function dominates, in congratulations or expressions of sympathy it is the phatic function, in research reports the representational function, in advertising the persuasive function, etc. Functional approach is present in the elaboration of functional perspective initiated by the Prague school of functional stylistics and the elaboration of the *theory of functional styles* (K. Havránek, M. Jelínek); it is also present in the approaches of Gal’perin (1977) who differentiates five functional styles of English (the publicistic, newspaper, scientific prose, belles-lettres styles and the style of official documents), and of Crystal and Davy (1969) who offered an in-depth analysis of five ‘languages’ (conversation, unscripted commentary, religion, newspaper reporting and legal documents), but suggested possibilities for the study of other varieties as well (the language of TV and press advertising, public speaking, written instructions, broadcast talks and news, science, the civil service and the spoken legal language). It should be noted that the variation based on the functional (contextual) criterion represents one of the three principal types of variation of national language (the other two being regional and social variation). Using the degree of abstraction (generalization) as the main criterion of text typology, the functional styles could stand at the top, followed by the styles of particular social groups and/or traditions of literary writing (interindividual styles), the styles of an individual authors (individual or personal styles) and the styles of individual texts (singular styles). The criterion of the ‘global area of activity’ as proposed by Dolník and Bajzíkova is close to the identification of functional styles in that they identify journalistic, economic, political, legal and scientific texts. We consider this empirically based text classification firmly rooted in the structural-functional theory of text (toward which language users intuitively orient) as a viable approach since it integrates the criteria of communicative function, situation (context) and strategy.

2.a. Functional classification

The functional classification identifies text types according to the type of the dominating act: representative or assertive type (e.g., research reports, public notices, administrative texts, weather forecasts, diaries, CVs, lectures), directive type (e.g., commands, orders, invitations, instructions, directions, giving advice), expressive type (e.g., apologies, thank-you notes, greetings, condolences, compliments, toasts, congratulations), commissive type (e.g., promises, pledges, swears, offers, vows, contracts, bets), declarative or performative type (e.g., nominations, appointments, dismissals, accusations: I find you guilty as charged, marriage ceremonies, testaments, certificates). Texts viewed from this perspective satisfy diverse communicative needs of the society members.

2.b. Situational classification

The situational classification sorts out texts according to the “sphere of activity” (e.g., private, official or public, such as a private letter, a letter addressed to an institution) and ‘form of communication’ (dialogical and monological, spoken and written texts).

2.c. Strategic classification

The strategic classification deals primarily with the topic and the ways of its expansion: *narrative, descriptive, and argumentative*.

2.c.1. Narration, considered to be the most common and culture-universal genre, in its basic (unmarked) way of presentation it follows a series of structural steps forming its universal template:

- a) abstract providing a “title” for a story;
- b) orientation giving information on the time, setting, characters and their roles;
- c) complicating action presenting a “problem” which must be overcome by characters in order to attain their goal;
- d) resolution signalling the attainment of the goal;
- e) coda bringing the story ‘back’ to the beginning by providing a moral, summary, relevance, etc.

Evaluation, dispersed throughout a narrative (e.g., in the form of bracketed asides or side sequences), may contribute to the upkeep of suspense and listeners’ involvement. Alternatively, stories may rearrange the unmarked sequence of steps (departing thus from the principle of iconicity) by their beginning at various points in narrative (e.g., in medias res). While individual steps are conventionally signalled by sets of markers (e.g., One summer’s day ...), the right for the provision of an uninterrupted turn for the narrator is claimed by a ‘ticket’ (Did I ever tell you about ... ?, or Something similar happened to me once ...). The plot in narrative fiction is based on a parallel principle: exposition, conflict and dénouement (or “unknotting”, resolution).

2.c.2. Description of a static type lists typical features of an object or topic described in an orderly fashion: from more to less important features, from a whole to its parts, from the outside to the inside, etc. In dynamic (processual, procedural) descriptions a temporal order of procedures is binding (e.g., recipes for making a food dish, instruction manuals). Static descriptions make frequent use of presentatives (there is/are), relative clauses, descriptive adjectives, prepositional and adverbial phrases; procedural descriptions abound in imperatives, passive constructions, purpose clauses (To switch to a different line ...), impersonal constructions (It is advisable to make a backup copy of your disks), but also in assertions understood as directives (You use environment variables to control the behaviour of some batch files ...), etc.

2.c.3. Argumentation has been identified as “the basic organizational force underlying all linguistic communication“ (Verschueren 1999:46). Hatch (1992) offers the following stages of a classical model of argumentation: introduction, explanation of the case under consideration, outline of the argument, proof, refutation (i.e., disproof) and conclusion. The genre has many variants (cf. Schiffrin’s (1987) three stages: position, dispute and support) and may be culturally determined. Some authors identify explication (Dolník and Bajžíková 1998) as a specific strategy whereby the nature of phenomena is explained, and information (Mistrík 1997) which provides a simple list of relevant features regardless of their mutual relations. The elaboration of a fully exhaustive and universally applicable method of text typology remains one of the most challenging tasks of text linguistics, stylistics and rhetoric.

3. Text and discourse

3.a. The nature of text

When we think of a text we typically think of a stretch of language complete in itself and of some considerable extent: a business letter, a leaflet, a news report, a recipe, and so on. However, though this view of texts may be commonsensical, there appears to be a problem when we have to define units of language which consist of a single sentence, or even a single word, which are all the same experienced as texts because they fulfill the basic requirement of forming a meaningful whole in their own right. Typical examples of such small texts are public notices like KEEP OFF THE GRASS, KEEP LEFT, KEEP OUT, DANGER, SLOW, EXIT. It is obvious that these minimal texts are meaningful in themselves, and therefore do not need a particular structural patterning with language units. In other words, they are complete in terms of communicative meaning. For the expression of its meaning, a text is dependent on its use in an appropriate context.

3.b. *The nature of discourse*

The meaning of a text does not come into being until it is actively employed in a context of use. This process of activation of a text by relating it to a context of use is what we call *discourse*. To put it differently, this contextualization of a text is actually the reader's (and in the case of spoken text, the hearer's) reconstruction of the writer's (or speaker's) intended message, that is, his or her communicative act or discourse. In these terms, the text is the observable product of the writer's or speaker's discourse, which in turn, must be seen as the process that has created it. Clearly, the observability of a text is a matter of degree: for example, it may be in some written form, or in the form of a sound recording, or it may be unrecorded speech. But in whatever form it comes, a reader (or hearer) will search the text for cues of signals that may help to reconstruct the writer's or speaker's discourse. However, just because he or she is engaged in a process of reconstruction, it is always possible that the reader (or hearer) infers a different discourse from the text than the one, the writer (or speaker) had intended. Therefore, one might also say that the inference of discourse meaning is largely a matter of negotiation between writer (speaker) and reader (hearer) in a contextualized social interaction. So, a text can be realized by any piece of language as long as it is found to record a meaningful discourse when it is related to a suitable context of use.

At this point, it will have become clear that in order to derive a discourse from a text we have to explore two different sites of meaning: on the one hand, the text's intrinsic linguistic or formal properties (its sounds, typography, vocabulary, grammar, and so on) and on the other hand, the extrinsic contextual factors which are taken to affect its linguistic meaning. These two interacting sites of meaning are the concern of two fields of study: *semantics* – the study of formal meanings as they are encoded in the language of texts, that is independent of writers (speakers) and readers (hearers) set in a particular context, and *pragmatics* concerned with the meaning of language in discourse, that is when it is used in an appropriate context to achieve particular aims. Pragmatic meaning is not, we should note, an alternative to semantic meaning, but complementary to it, because it is inferred from the interplay of semantic meaning with the context. We distinguish two kinds of context: an internal linguistic context built up by the the language patterns inside the text, and an external non-linguistic context drawing us to ideas and experiences in the world outside the text. The latter is a very complex notion because it may include any number of text-external features influencing the interpretation of the discourse. Perhaps we can make the notion more manageable by specifying the following components (obviously, the list is by no means complete):

- the text type, or genre (for example, an election poster, a recipe, a sermon);
- its topic, purpose, and function;
- the immediate temporary and physical setting of the text;
- the text's wider social, cultural, and historical setting;
- writer (speaker) and reader (hearer);
- the relationships holding between the writer (speaker) and reader (hearer);
- the associations with other similar or related text types (intertextuality);

Self-check test

1. What is text linguistics?
2. What are the possible classifications of texts?
3. What does functional classification of texts include?
4. What does situational classification of texts include?
5. What does strategic classification of texts deal with?
6. Describe the nature of text.
7. What makes the nature of discourse?
8. Point to the difference between textual and contextual meaning.

Recommended Readings

1. Beaugrande R. de, Dressler W. Introduction to Text Linguistics. – Longman Pub Group, 1981. – 288 p.
2. Clark E. History, Theory, Text: Historians and the Linguistic Turn. – Harvard University Press, 2004. – 336 p.
3. Halliday M. A.K. Linguistic Studies of Text and Discourse.– Continuum, 2006. – 320 p.
4. Forey G., Thompson G. Text Type and Texture (Functional Linguistics). – Equinox Publishing, 2010. – 304 p.
5. Jargen E. Introduction to English Text-linguistics (Textbooks in English Language and Linguistics). – Peter Lang, 2009. – 210 p.
6. Rudanko J. Linguistic Analysis and Text Interpretation. – University Press of America, 1997. – 144 p.
7. Salkie R. Text and Discourse Analysis (Language Workbooks). – Routledge, 1995.– 128 p.
8. Titscher S., Meyer M., Wodak R. Methods of Text and Discourse Analysis.– Sage Publications Ltd, 2000. – 288 p.
9. Virtanen T. Approaches to Cognition through Text and Discourse (Trends in Linguistics. Studies and Monographs). – Mouton De Gruyter, 2004. – 350 p.

Lecture 10

Components of communication connected with communicative situation

Plan

- 1. Styles of communication.*
- 2. The system of functional styles.*
- 3. Rhetoric and communication.*
- 4. Cross-cultural communication.*

1. Styles of communication

Every time we speak, we choose and use one of four basic communication styles: assertive, aggressive, passive and passive-aggressive.

Assertive communication

The most effective and healthiest form of communication is the assertive style. It's how we naturally express ourselves when our self-esteem is intact, giving us the confidence to communicate without games and manipulation. When we are being assertive, we work hard to create mutually satisfying solutions. We communicate our needs clearly and forthrightly. We care about the relationship and strive for a win situation. We know our limits and refuse to be pushed beyond them just because someone else wants or needs something from us. Surprisingly, assertive is the style most people use least.

Aggressive communication

Aggressive communication always involves manipulation. We may attempt to make people do what we want by inducing guilt (hurt) or by using intimidation and control tactics (anger). Covert or overt, we simply want our needs met – and right now! Although there are a few arenas where aggressive behavior is called for (i.e., sports or war), it will never work in a relationship. Ironically, the more aggressive sports rely heavily on team members and rational coaching strategies. Even war might be avoided if we could learn to be more assertive and negotiate to solve our problems.

Passive communication

Passive communication is based on compliance and hopes to avoid confrontation at all costs. In this mode we don't talk much, question even less, and actually do very little. We just don't want to rock the boat. Passives have learned that it is safer not to react and better to disappear than to stand up and be noticed.

Passive-aggressive communication

A combination of styles, passive-aggressive avoids direct confrontation (passive), but attempts to get even through manipulation (aggressive). If you've ever thought about making that certain someone who needs to be "taught a thing or two" suffer (even just a teeny bit), you've stepped pretty close to (if not on into) the devious and sneaky world of the passive-aggressive. This style of communication often leads to office politics and rumour-mongering.

Clearly, for many reasons, the only healthy communication style is assertive communication. Surely you can identify many people in your own life that favor each of the four styles. Most of us use a combination of these four styles, depending on the person or situation. The styles we choose generally depend on what our past experiences have taught us will work best to get our needs met in each specific situation. If you take a really good look at yourself, you've probably used each throughout your lifetime. Understanding the four basic types of communication will help learn how to react most effectively when confronted with a difficult person. It will also help recognize when you are using manipulative behavior to get your own needs met. Remember, you always have a choice as to which communication style you use. If you're serious about taking control of your life, practice being more assertive. It will help you diffuse anger, reduce guilt and build relationships – both personally and professionally.

Communication styles and communication style modes (by Christopher L. Heffner)

Christopher L. Heffner singles out 3 communication styles. They are passive, assertive, aggressive. Table 1 points to typical characteristics of each of the styles.

Communication Styles by Christopher L. Heffner

	Passive	Assertive	Aggressive
Definition	Communication style in which you put the rights of others before your own, minimizing your own self worth	Communication style in which you stand up for your rights while maintaining respect for the rights of others	Communication style in which you stand up for your rights but you violate the rights of others
Implications to Others	my feelings are not important I don't matter I think I'm inferior	we are both important we both matter I think we are equal	your feelings are not important you don't matter I think I'm superior
Verbal Styles	apologetic overly soft or tentative voice	I statements firm voice	you statements loud voice
Non-Verbal Styles	looking down or away stooped posture, excessive head nodding	looking direct relaxed posture, smooth and relaxed movements	staring, narrow eyes tense, clenched fists, rigid posture, pointing fingers
Potential Consequences	lowered self-esteem anger at self false feelings of inferiority disrespect from others pitied by others	higher self -esteem self respect respect from others respect of others	guilt anger from others lowered self-esteem disrespect from others feared by others

Individuals have various preferences for both communicating *with* others and interpreting the communications *from* others. Numerous models have been developed which describe how to recognize an individual's preferred style of communicating and what strategy to use in communicating most effectively with them. Christopher L. Heffner identifies 4 different personality types: *expresser*, *driver*, *relater*, *analytical*. Table 2 describes different communication style modes.

COMMUNICATION STYLE MODES

FACTORS:	EXPRESSER	DRIVER	RELATER	ANALYTICAL
How to Recognize:	They get excited.	They like their own way; decisive & strong viewpoints.	They like positive attention, to be helpful & to be regarded warmly.	They seek a lot of data, ask many questions, behave methodically.
Tends to Ask:	Who? (the personal dominant question)	What (the results oriented question.)	Why? (the personal non-goal question.)	How? (the technical analytical question.)
What They Dislike:	Boring explanations with too many facts.	Someone wasting their time.	Rejection, treated impersonally, unfeeling attitudes.	making an error, being unprepared, spontaneity.
Reacts to Pressure and Tension By	"Selling" their ideas or argumentative.	Taking charge taking more control.	Becoming silent, withdraws, introspective.	Seeking more data & information.
Best way to Deal With:	Get excited with them. Show emotion.	Let them be in charge.	Be supportive; show you care.	Provide lots of data & information.
Likes To Be Measured By:	Applause, feedback, recognition.	Results, Goal-oriented.	Friends, close relationships.	Activity & busyness that leads to results.
Must Be Allowed To:	Get ahead quickly. Likes challenges.	Get into a competitive situation.	Relax, feel, care, know you care.	make decisions at own pace, not pressured.
Will Improve With:	Recognition & some structure with which to reach the goal.	A position that requires cooperation with others.	A structure of goals & methods for achieving each goal.	Interpersonal and communication skills.
Likes to Save:	Effort they rely heavily on hunches, intuition, feelings.	Time. They like to be efficient, get things done now.	Relationships. Friendship means a lot to them.	Face. They hate to make an error, be wrong or get caught without enough info.
For Best Results:	Inspire them to bigger & better accomplishments.	Allow them freedom to do things their own way.	Care & provide detail, specific plans&activities to be accomplished.	Structure a framework or "track" to follow.

2. The system of functional styles

Functional style is a system of interrelated language means serving a definite aim in communication. It is the coordination of the language means and stylistic devices which shapes the distinctive features of each style and not the language means or stylistic devices themselves. Each style, however, can be recognized by one or more leading features which are especially conspicuous. For instance, the use of special terminology is a lexical characteristic of the style of scientific prose, and one by which it can easily be recognized. A style of language can be defined as a system of coordinated, interrelated and inter-coordinated language means intended to fulfill a specific function of communication and aiming at a defined effect. Style of language is a historical category.

The English literary system has evolved a number of styles easily distinguishable one from another. They are not homogeneous and fall into several variants of having some central point of resemblance or better to say. All integrated by the invariant – i.e. the abstract ideal system.

They are:

- 1) Official (documents and papers);
- 2) Scientific (brochures, articles, other scientific publications);
- 3) Publicistic (essay, public speech);
- 4) Newspaper style (mass media);
- 5) Belles-lettres style (genre of creative writing);

Each of the mentioned here styles can be expressed in two forms: written and oral.

1) Scientific style is employed in professional communication to convey some information. Its most conspicuous feature is the abundance of terms denoting objects, phenomena and processes characteristic of some particular field of science and technique. Also precision, clarity, logical cohesion.

2) Official style is the most conservative one. It uses syntactical constructions and archaic words. Emotiveness is banned out of this style.

3) Publicistic style is famous for its explicit pragmatic function of persuasion directed at influencing the reader in accordance with the argumentation of the author.

4) Newspaper style – special graphical means are used to attract the reader's attention.

5) Belles-lettres style – the richest register of communication besides its own language means, other styles can be used besides informative and persuasive functions, belles-lettres style has a unique task to impress the reader aesthetically.

3. Rhetoric and communication

The *traditional perspective*, based upon Aristotle's teachings, assumes that people are, by nature, subject to and capable of persuasion because, unlike other species, we have the capacity to be rational. Of course emotional, psychological, and

physiological factors also affect persuasion, but classical rhetoric insists that such appeals are subsidiary to, or contingent upon, judgments resulting from rational means of persuasion. Rhetoric is viewed as a battle of words, in which speakers attempt to overcome resistance to a course of action, an idea, or a particular judgment by effectively expressing their thoughts in particular situations. Rhetoric traditionally was considered to be public, contextual, and contingent. It was *public* because it affected the entire community and was typically performed before law courts, legislative assemblies and celebratory gatherings of citizens. Rhetoric was *contextual* because the meaning of a particular figure of speech or example derived from the particular experiences of a particular audience addressed by a particular speaker at a particular moment. Situations were *contingent* because the speaker couldn't know ahead of time what was most important or most necessary to say in order to persuade an audience. Unlike scientists who use systematic, empirical, and objective investigation, or artists who wish to create works with timeless quality, rhetors rely on probability and they seek timely and fitting action. All choices, from the arguments to the style of delivery, were assumed to be conscious decisions made to produce and intended effect on listeners. Critics sought an understanding of both a speaker's intentions and the potential effects upon an audience by asking why a speaker chose to talk about certain topics, why the artistic elements of his speech were structured as they were, why certain styles of speech were followed, and so forth. The critic's job was to assess how closely the speaker came to accomplishing what could have been achieved given the circumstances. The typical approach to neo-Aristotelian criticism was to use classical rhetorical categories to describe and explain oral persuasive messages. H. Wichelns explains that rhetorical criticism is necessarily analytical. The scheme of a rhetorical study includes the element of the speaker's personality as a conditioning factor; it includes also the public character of the man – not what he was but what he was thought to be. It requires a description of the speaker's audience, and of the leading ideas with which he plied his hearers – his topics, the motives to which he appealed, the nature of proofs he offered. These will reveal his own judgment of human nature in his audiences, and also his judgment on the questions which he discussed. Nor can rhetorical criticism omit the speaker's mode of arrangement and his mode of expression, nor his habit of preparation and his manner of delivery from the platform; though the last two are perhaps less significant. "Style" – in the sense which corresponds to diction and sentence movement must receive attention, but only as one among various means that secure for the speaker ready access to the minds of his auditors. Finally, the effect of the discourse on its immediate hearers is not to be ignored, neither in the testing of witnesses, nor in the record of events. And throughout such a study one must conceive of the public man as influencing the men of his own times by the power of his discourse. Neo-classical critics, following what they believed to be Aristotle's lead, disregarded many manifestations of symbolic meaning that were nonverbal and non-oral as being irrelevant to their concerns, and they further disregarded those oral modes of discourse that did not appear to exhibit patterns of (rational) reasoning. Beginning in 1970, however, the scope of rhetorical criticism was expanded to include nondiscursive subjects, and the next sections describe a few

of the more important examples of traditional perspective applied to visual forms of communication.

4. Cross-cultural communication

Cross-cultural communication (also frequently referred to as intercultural communication, which is also used in a different sense, though) is a field of study that looks at how people from differing cultural backgrounds communicate, in similar and different ways among themselves, and how they endeavour to communicate across cultures. Cross-cultural communication tries to bring together such relatively unrelated areas as cultural anthropology and established areas of communication. Its core is to establish and understand how people from different cultures communicate with each other. Its charge is to also produce some guidelines with which people from different cultures can better communicate with each other. Cross-cultural communication, as in many scholarly fields, is a combination of many other fields. These fields include anthropology, cultural studies, psychology and communication. The field has also moved both toward the treatment of interethnic relations, and toward the study of communication strategies used by co-cultural populations, i.e., communication strategies used to deal with majority or mainstream populations. The study of languages other than one's own can not only serve to help us understand what we as human beings have in common, but also assist us in understanding the diversity which underlies not only our languages, but also our ways of constructing and organizing knowledge, and the many different realities in which we all live and interact. Such understanding has profound implications with respect to developing a critical awareness of social relationships. Understanding social relationships and the way other cultures work is the groundwork of successful globalization business efforts. Language socialization can be broadly defined as "an investigation of how language both presupposes and creates new, social relations in cultural context". It is imperative that the speaker understands the grammar of a language, as well as how elements of language are socially situated in order to reach communicative competence. Human experience is culturally relevant, so elements of language are also culturally relevant. One must carefully consider semiotics and the evaluation of sign systems to compare cross-cultural norms of communication. There are several potential problems that come with language socialization, however. Sometimes people can over-generalize or label cultures with stereotypical and subjective characterizations. Another primary concern with documenting alternative cultural norms revolves around the fact that no social actor uses language in ways that perfectly match normative characterizations. A methodology for investigating how an individual uses language and other semiotic activity to create and use new models of conduct and how this varies from the cultural norm should be incorporated into the study of language socialization.

However, with the process of globalization, especially the increasing of global trade, it is unavoidable that different cultures will meet, conflict, and blend together.

People from different cultures find it is hard to communicate not only due to language barrier but also affected by culture styles. For instance, in independent cultures, such as in the United States, Canada, and Western Europe, an independent figure of self is dominant. This independent figure is characterized by a sense of self relatively distinct from others and the environment. In interdependent cultures, usually identified as Asian as well as many Latin American, African, and Southern European cultures, an interdependent figure of self is dominant. There is a much greater emphasis on the interrelatedness of the individual to others and the environment, the self is meaningful only (or primarily) in the context of social relationships, duties, and roles. In some degree, the effect brought by cultural difference override the language gap. And this culture style difference contributes to one of the biggest challenge for cross-culture communication. Effective communication with people of different cultures is especially challenging. Cultures provide people with ways of thinking—ways of seeing, hearing, and interpreting the world. Thus, the same words can mean different things to people from different cultures, even when they talk the "same" language. When the languages are different, and translation has to be used to communicate, the potential for misunderstandings increases. The study of cross-cultural communication is fast becoming a global research area. As a result, cultural differences in the *study* of cross-cultural communication can already be found. For example, cross-cultural communication is generally considered to fall within the larger field of communication studies in the US, but it is emerging as a sub-field of applied linguistics in the UK. As the application of cross-cultural communication theory to foreign language education is increasingly appreciated around the world, cross-cultural communication classes can be found within foreign language departments of some universities, while other schools are placing cross-cultural communication programs in their departments of education.

There are several parameters that may be perceived differently by people of different cultures. These may include:

- ***Perception of Time***: in some countries like China and Japan, punctuality is considered important and being late would be considered as an insult. However, in countries such as those of South America and the Middle East, being on time does not carry the same sense of urgency.
- ***Perception of Space***: the concept of "personal space" also varies from country to country. In certain countries it is considered respectful to maintain a distance while interacting. However, in other countries, this is not so important.
- ***Non-verbal Communication***: cultures may be either *low-context* or *high-context*: low-context cultures rely more on content rather than on context. They give value to the written word rather than oral statements. High-context cultures infer information from message context, rather than from content.

They rely heavily on nonverbal signs and prefer indirectness, politeness and ambiguity.

Self-check test

1. Describe basic communication styles.
2. What are typical features of communication styles singled out by Christopher L. Heffner?
3. What are 4 different personality types identified by Christopher L. Heffner?
4. What is functional style?
5. Describe each of the functional styles.
6. What is rhetoric?
7. Point to the connection between rhetoric and communication.
8. What is cross-cultural communication?
9. What parameters are perceived differently by people of different cultures?

Recommended Readings

1. Booth W. *The Rhetoric of RHETORIC: The Quest for Effective Communication* (Blackwell Manifestos). – Wiley-Blackwell; 1 edition, 2014.– 224 p.
2. Bryant D. *The Rhetorical Idiom: Essays in Rhetoric, Oratory, Language and Drama* (Presented to Herbert August Wichelns with a reprinting of his "Literary Criticism of Oratory"). – Cornell University Press.– First Printing edition, 1958. – 334 p.
3. Carey J. *Communication as Culture: Essays on Media and Society*. – Winchester, MA: Unwin Hyman, 2009. – 213 p.
4. Goatly A. *Explorations in Stylistics (Functional Linguistics)*. – Equinox Publishing, 2018. – 224 p.
5. Enos T. *Encyclopedia of Rhetoric and Composition: Communication from Ancient Times to the Information Age*. – Routledge; 1 edition, 2010.– 832 p.
6. Keteyian R. *Do You Know What I Mean?: Discovering Your Personal Communication Style*. – Create Space, 2011. – 144 p.
7. Rogers E., Steinfatt T. *Intercultural Communication*. – Waveland Press, 1998. – 292 p.
8. Samovar L. *Communication between Cultures*. – Wadsworth Publishing; 7th edition, 2009. – 480 p.
9. Selber S., Miller C. *Rhetorics and Technologies: New Directions in Writing and Communication (Studies in Rhetoric/Communication)*. – University of South Carolina Press, 2019. – 232 p.
10. Strunk W., White E. *The Elements of Style: 50th Anniversary Edition*. – Longman; 1 edition, 2018. – 128 p.

Lecture 11

Speech act in the structure of message (communication) Plan

1. *The origin and development of speech act theory. J.Austin's "How to do things with words".*
2. *Defining the speech act*
 - 2.1. *The components of the speech act.*
 - 2.2. *John Searle's explanation of the constituent parts of the speech act.*
 - 2.3. *The interpretations of the definition of the speech act by J. Austin and J. Searle's followers.*
3. *The classification of speech act*

1. The origin and development of speech act theory. J.Austin's "How to do things with words"

Speech act theory attempts to explain how speakers use language to accomplish intended actions and how hearers infer intended meaning from what is said. Although speech act studies are now considered a subfield of pragmatics but actually these studies go back to the philosophy of language. Philosophers like J. Austin, P. Grice, and J. Searle investigated this new theory of linguistic communication based on the assumption that "... the minimal units of human communication are not linguistic expressions, but rather the performance of certain kinds of acts, such as making statements, asking questions, giving directions, apologizing, thanking, and so on".

From the ancient times until nowadays, philosophers and scientists have always paid attention to the problem of expressing thoughts. Many works are devoted to this issue. During the long period, the main efforts of linguists have been dedicated to the studying of the structural and semantic characteristics of the different languages. Therefore, the term 'pragmaticus' is found in Late Latin and 'pragmaticos' in Greek, with the meaning 'of being practical'. Beginning from the Aristotle epoch, scientists try to systematize and in some way classify the whole multiparty system of the forms and means of the expression of the human thought. For this reason, it is not strange that such aspect as studying and description of the formal and structural features of the sentences is one of best studied parts in the theory of sentences.

About two thousand years ago, Aristotle noticed that "language was determinate with regard to matters of truth and falsity – any linguistic expression was an instance of logos semantikos (i.e. it had a meaning, it signified something) but not all expressions were true or false (of the three types of logoi – apophatikos, pragmatikos and poetikos – only the first could be tested for its truth value)" [66].

Unfortunately, he studied the language only from the point of view of rhetoric and poetry, but still his works are fundamental for the development of speech act theory. His works include that information, which has been used by the famous scientists such as J. Austin and J. Searle in their investigations.

Two philosophers can, however, be credited with having made early efforts to the development of the speech act theory. The first, significantly, is Thomas Reid, who defines that “the principles of the art of language are to be found in a just analysis of the various species of sentences” and adds that “Aristotle and the logicians have analyzed one species – to wit, the *proposition*. To enumerate and analyze the other species must, I think, be the foundation of a just theory of language”. T. Reid also provides the technical term for such uses of language as promisings, warnings, forgivings, and so on, he calls them ‘social operations’. However, we must admit that sometimes he also calls them ‘social acts’, opposing them to ‘solitary acts’ such as judgings, intendings, deliberatings and desirings.

The second is Adolf Reinach, a member of a group of followers of Husserl based in Munich in the early years of the last century. A. Reinach investigated social acts, the achievements of which he presented in his monograph *The A Priori Foundations of the Civil Law*, which was published in 1913 (four years before his death on the Western Front). As Barry Smith says about this book: “...he concentrated especially on the act of promising, applying his method also to the analysis of legal phenomena such as contract and legislation and describing the theory which results as a ‘contribution to the general ontology of social interaction’”.

The main value of Adolf Reinach’s book is that his followers, J. Austin and J. Searle, will study those elements of writing investigated by him. However, unfortunately, as Barry Smith underlines that “The Reinach’s theory of social acts was doomed, like T. Reid’s theory of social operations before it, to remain almost entirely without influence”.

At the beginning of the twentieth century, the linguistic thought centered around the problem of studying semantic aspects of the syntactical structures. Different scientific schools appeared at that time. One of them was in Vienna. It should be mentioned that these neo-positivist scholars of the Vienna Circle forgot much of Aristotle’s lesson. Rather dissatisfied with the everyday language, they made their primary task translate ordinary sentences into a better (i.e. more logical) wording. R. Carnap formulated the two necessary and sufficient conditions under which a sentence could be deemed significant: “A proposition was “logically correct” and meaningful if and only if it could either be confirmed by empirical evidence or derived through successive inferences from correct premises” [66]. Obviously enough, as Maria Ștefanescu says, R. Carnap’s position is strongly reductionistic and, in a peculiar way, dogmatic – it proclaims the universal validity of certain criteria and claims that any sentence which fails to meet them is, strictly speaking, meaningless. One of the most prominent scientists in pragmatics is John Austin. J. L. Austin’s epoch is connected with his book *How to Do Things with Words* (at first, a series of lectures delivered at Harvard University in 1955), this

book is directed against the oversimplified view of language. A central tenet of J. Austin's theory is that no philosophical school can afford to study language in itself, without paying any attention to pragmatic aspects. To abstract artificially sentences and then propositions from real everyday talk and to confine one's interest to them alone is to elude the great complexity of linguistic communication. The right path towards giving a fairly accurate account of how language works does not involve the construction of artificial logical systems but rather "very detailed and minute studies of ordinary language – studies through which, it is hoped, its richness may be revealed by making explicit the distinctions of which we usually have only a confused knowledge and by describing the disparate functions of many sorts of linguistic expressions".

J. Austin's first move in *How to Do Things with Words* is to question the validity of the assumption that the main function of language is to give a true or false description of objective reality. According to J. Austin, there are actually numberless utterances to which one cannot ascribe any truth-value at all. However, he underlines that under the specific conditions or circumstances, statements which at first can be regarded as meaningless start to have completely different meanings. J. Austin explains that there are sentences which we used not to describe some situation, but to make someone do a particular action, he says that "to utter the sentence (in, of course, the appropriate circumstances) is not to *describe* my doing of what I should be said in so uttering to be doing or to state that I am doing it: it is to do it".

Such type of sentences J. Austin calls 'performative sentences' or a performative utterance, he also uses a shorten form 'a performative'. The name derives from the word 'to perform'. When one apologizes or complains or promises something or proposes marriage or even performs one, he does not describe any preexistent state of affairs nor points to any external reality but rather produces a conventional referent by the very issuing of that particular utterance. In other words, there is a category of verbs so-called "performative verbs" ('to bet', 'to request', 'to threaten', 'to congratulate', 'to welcome', 'to declare war', 'to baptize' and so on) – which, when used in their performative function, actually do things.

In his book, J. Austin points out that some utterances should not be regarded as false or true, but as the actions which have been brought off happily and those where something has gone wrong, that is ones that have failed. Such speech acts, according to J. Austin, we cannot indeed name as false, as far as he uses another word 'unhappy'. Therefore, his doctrine of Infelicities we use to refer to 'the doctrine of the things that can be and go wrong' [32, p.14]. One's promise, J. Austin says, will never be true or false but it can turn out to be felicitous or infelicitous. The success or failure of such utterances is a matter of collective accord and depends on the agreements observed by various sociolinguistic communities. In *How to Do Things with Words*, J. Austin provides a list of what he calls the "felicity conditions" for any performative utterance:

"(A.1) There must exist an accepted conventional procedure having a certain conventional effect, that procedure to include the uttering of certain words by certain persons in certain circumstances, and further, (A.2) the particular

persons and circumstances in a given case must be appropriate for the invocation of the particular procedure invoked. (B.1) The procedure itself must be executed by all participants both correctly and (B.2) completely. (C.1) Where, as often, the procedure is designed for use by persons having certain thoughts or feelings for the inauguration of certain consequential conduct on the part of any participant, then a person participating in and so invoking the procedure must in fact have those thoughts or feelings, and the participants must intend so to conduct themselves and further, (C.2) must actually so conduct themselves subsequently”.

J. Austin divides the various types of infelicity into two groups. The rules A and B represent the first group and C – the second. This differentiation is made in order to point out difference between “misfires” (the cases when the intended action *fails to come off* owing to inappropriate circumstances) and “abuses” (when the act *is executed* but infelicitously – for instance, a promise made in bad faith).

J. Austin’s technique of constantly questioning makes him give up the idea that performatives are accidental aspects of speech, in favour of the view that there is a large class of performative utterances, which includes both explicit and implicit performatives. In addition, after some period, he replaces the constative-performative dichotomy with an overall theory of illocutionary acts: “The doctrine of the performative/constative distinction stands on the doctrine of locutionary and: illocutionary acts in the total speech act as the *special* theory to the *general* theory. And the need for the general theory arises simply because the traditional ‘statement’ is an abstraction, an ideal, and so is its traditional truth/falsity”.

In his work, J. Austin emphasizes that stating is performing an act. The conclusion of J. Austin’s work may be given in the shape of a summary: “We first distinguished a group of things we do in saying something, which together we summed up by saying we perform a *locutionary act*, which is roughly equivalent to uttering a certain sentence with a certain sense and reference, which again is roughly equivalent to ‘meaning’ in the traditional sense. Secondly we said that we also perform *illocutionary acts* such as informing, ordering, warning, undertaking etc., i.e. utterances which have a certain (conventional) force. Thirdly, we may also perform *perlocutionary acts*: what we bring about or achieve *by* saying something, such as convincing, persuading, deterring and even, say, surprising or misleading.

One of the main merits of J. Austin’s work is that he gives the definition of the speech act. It should be mentioned that the contemporary use of the term goes back to J. Austin’s doctrine of locutionary, illocutionary and perlocutionary acts. According to J. Austin’s theory, speech acts have prepositional or locutionary meaning (the literal meaning of the utterance), illocutionary meaning (the social function of the utterance), and perlocutionary force (the effect produced by the utterance in a given context).

By the end of *How to Do Things with Words*, however, J. Austin gives up on the idea of the theory of performatives as such. He comes to this conclusion because he understands that utterances are performative in nature. Therefore, in his further researches, he focuses mainly on the investigating of the peculiarities of the speech acts in general and on the gathering of the examples of the speech acts.

2. Defining the speech act

2.1. The components of the speech act. Despite the fact that there is no one thought as to the components of the speech act, the majority of the scientists agree that the locutionary, illocutionary and perlocutionary acts are, in fact, three basic components with the help of which a speech act is formed. G. Leech briefly defines them like this:

locutionary act: performing an act of saying something;

illocutionary act: performing an act in saying something;

perlocutionary act: performing an act by saying something.

The locutionary act can be viewed as a real uttering of some words in certain language, while the illocutionary and perlocutionary acts express a more complicated message for the hearer. By the illocutionary act, the speaker presents his/her intention but the locution and a perlocutionary acts are used to show the effect that the speaker wants to achieve. However, the individual elements cannot be always separated that easily.

K. Bach and R. Harnish say that “the locutionary, illocutionary and perlocutionary acts are intimately related in a large measure”. However, for better understanding of their function within a speech act, we are going to treat them individually.

Locutionary acts:

This component of the speech act is probably the least ambiguous. K. Bach and R. Harnish commenting on J. Austin’s work, point out that J. Austin distinguishes three aspects of the locutionary act.

J. Austin claims that to say anything is:

A. always to perform the act of uttering certain noises (a phonetic act)

B. always to perform the act of uttering certain vocables or words (a phatic act)

C. generally to perform the act of using that [sentence] or its constituents with a certain more or less definite ‘sense’ and a more or less definite ‘reference’, which together are equivalent to ‘meaning’ (rhetic act).

J. Searle warns that J. Austin’s rhetic act is “nothing else but a reformulated description of the illocutionary act and he therefore suggests another term, the so-called propositional act which expresses the proposition (a neutral phrase without illocutionary force)”. In other words, a proposition is the content of the utterance.

R. Wardhaugh offers the following explanation: “Propositional acts are those matters having to do with referring and predicating: we use language to refer to matters in the world and to make predictions about such matters”. He also stresses that propositional acts cannot occur alone since such speech act would be defined as incomplete. The proposition is thus expressed in the very performance of an illocutionary act.

Utterance acts together with propositional acts are an important part of the theory of speech acts, but linguists pay more attention to the problem of the classification of the illocutionary acts.

Illocutionary acts:

Illocutionary acts are considered the core of the theory of speech acts. As it has been already suggested above, an illocutionary act is the action performed by the speaker in producing a given utterance. The illocutionary act is closely connected with the speaker's intentions, e.g. stating, questioning, promising, requesting, giving commands, threatening and many others. As G. Yule claims "the illocutionary act is thus performed via the communicative force of an utterance which is also generally known as illocutionary force of the utterance". Basically, the illocutionary act indicates how the whole utterance is to be taken in the conversation.

Sometimes it is not easy to define the kind of illocutionary act. There are many hints that help us to determine the proper illocutionary act, such as the usage of the performative verb or stress, timbre and intonation, word order. All these hints or, in other words, "factors influencing the meaning of the utterance are called Illocutionary Force Indicating Devices, or IFID as Yule, referring to previous Searle's work, calls them".

To decode correctly that is to understand the illocutionary act uttered by the speaker, it is essential for the hearer to know the context in which the speech act occurs. Another specific feature of the illocutionary act is that they can be typical only for some cultures such speech acts are called 'culture-specific', therefore, they cannot be used universally. It should be mentioned that the problem of defining of the illocutionary acts can be quite complicated, because as a lot of scholars say, one and the same utterance can have more illocutionary forces (meanings) depending on the IFIDs, the context, the conventions and other factors.

Perlocutionary acts:

Perlocutionary acts, J. Austin's last element in the three-fold definition of speech acts, are uttered with the intention of producing a further effect on the hearer.

Sometimes we may think that perlocutionary acts are like illocutionary acts, yet there is one essential feature with the help of which we differentiate them. For example, if we take into account such sentence as "Close the door, please!". As an illocutionary act, it is a request and this act will be successful if the hearer understands that he should close the door, but as a perlocutionary act it can be consider successful only in case the interlocutor closes the door.

2.2. John Searle's explanation of the constituent parts of the speech act.

It is beyond doubt that the second great contribution to the development of the speech act theory belongs to the American philosopher J. R. Searle. One could say, nevertheless, that the two important books that have been published by Searle on this issue are also, according to Maria Shtefanescu, "a little of a hindrance to the progress of the theory". It should be mentioned that he criticizes J. Austin's characterizations in terms of loose "family relationships" and provides his own rules and conditions that are necessary for the speech acts.

John Searle states that the speech communication is the production of the speech acts. The important characteristic of speech acts is that they are produced according to certain rules of the language. According to J. Searle, speech acts are the

main units of communication, because speech is primary and more significant than language. Thus, he considers speech act to be the minimal communication unit, a unity of the utterance proper as a sequence of words in the sentence.

In addition, Maria Shtefanescu emphasizes that the major problem for Searle is how to “link illocutionary force with such illocutionary force indicating devices (IFIDS) as performative verbs, word order, stress, intonation contour, punctuation, the mood of the verbs etc.” [66]. In order to find out the way, he tries to make the distinction between regulative rules and constitutive rules: the former control existing activities (e.g. traffic regulations), whereas the latter create the activities themselves. As a result, J. Searle concludes that there is a set of adequacy conditions that are not similar to the conditions that have been marked by J. Austin, the main among the conditions is “the essential condition”. The other three conditions are the preparatory condition, the propositional content condition (it concerns real-world constraints on the meaning of utterances) and the condition on sincerity. We must admit that the J. Searle’s division of the adequacy conditions is close to the J. Austin’s (despite S. Petrey’s opinion that “the American philosopher privileges the present definition of the act performed – X counts as Y – over the prior social reality necessary for speech to act, in fact Searle *does* take into account the *conventional* nature of all constitutive rules”). However, despite the similarities, they have different points of view about the sincerity condition.

J. Searle’s explanation of the constituent parts of the speech act differs from J. Austin’s. We may say that it happens because J. Searle changes a lot J. Austin’s suppositions, but the central notions of illocution and perlocution are expressed in their initial meanings. The great changes in explanations are connected with the locutionary act. J. Searle pays great attention to the perlocutionary content of the speech acts. This can be noticed in his book, which is dedicated to the investigation of the speech acts as far as the very first sentence of the book is “How do words relate to the world?”. But, although he states that “to know the meaning of a general term and hence a predicative expression is to know under what conditions it is true/false of a given objects” and that “If a speaker asserts a proposition concerning an object he commits himself to there being the state of affairs in the world in which the predicate is true of the object (and mutatis mutandis for other kinds of speech acts). The predication indicates which state of affairs concerning the objects the speaker is committing himself to”. J. Searle keeps in mind the distinction between the real facts and institutional facts. He even understands that there is a possibility that “the propositional acts can never occur, alone i.e. one cannot just refer or predicate without performing at the same time some other illocutionary act”.

After that discovery in his investigations, he concludes that there exists the “principle of expressibility” (whatever can be meant can be said), J. Searle discusses some of its “wide consequences” among which two are of great importance:

- 1) “the cases where the speaker does not say exactly what he means - the principal kinds of cases of which are nonliteralness, vagueness, ambiguity and incompleteness - are not theoretically essential to linguistic communication.
- 2) [the principle of expressibility] enables us to equate rules for performing

speech acts with rules for uttering certain linguistic elements, since for any possible speech act there is a possible linguistic element the meaning of which (given the context of utterance) is sufficient to determine that its literal utterance is a performance of precisely that speech act. To study the speech acts of promising/apologizing we need only study sentences whose literal and correct utterance would constitute making a promise or issuing an apology”.

We should mention that J. Searle’s point of view is not perfect as far as he “tries to play down the importance of those cases, rather thorny for his theory, when the speaker’s intent and the sentence meaning are at variance”. The difference between J. Austin and J. Searle lies in the fact that J. Austin investigates the peculiarities of the speech only to study the felicity conditions, whereas J. Searle begins his investigation from the language rules and researches of the things that are correct or incorrect in language. The latter consequence of the principle of expressibility, can be express in such form: “Whenever the illocutionary force of an utterance is not explicit it can always be made explicit”. This consequence makes him speak about so-called “literal force hypothesis” (according to S. Levinson, explicit performatives have the literal force named by the verb in the main clause and that the three major types of sentences in English, have the forces traditionally associated with them – stating, questioning and ordering). According to Maria Shtefanescu, “any utterance the illocutionary force of which cannot be identified with the aid of either of the two above mentioned rules, i.e. any indirect speech act, will be treated as an uncomfortable exception. Ruth Kempson analyzes illocutionary speech acts and concludes that those utterances that are lack of the specific ‘illocutionary force indicator’ can be used in different ways. Therefore, she comes to the conclusion that “a speech act semantics – if it is intended as a semantic characterization of the sentences of a language – is committed to predicting that all sentences of the language are multiply ambiguous” [46, p.59]. Thus, J. Searle is one of the foundation fathers of the speech act theory, his investigations are very important for linguistics, as far as they reveal the main properties of the speech acts.

2.3. The interpretations of the definition of the speech act by J. Austin and J. Searle’s followers.

Among the other scientists, who have paid attention to the problem to the definition of the speech act, are Peter Grice, Daniel Vanderveken, Davies Samuel, Ivan Susov, Oleh Pocheptsov.

Peter Grice regards the speech acts as the principle sphere of the discourse analysis. He defines speech acts as “a meaningful utterance, which consist of an utterance chain, delimited by pauses or change of the speaker is utterances, which makes sense and has any fact”. According to him, a speech act can be equal both to a word and the sequence of sentence utterances:

e.g. Out! – it is a speech act.

D. Vanderveken considers the illocutionary force to be the main component of the speech act. J. Campbell unites J. Austin and J. Searle approaches and concludes that the speech act consists of four main components:

- Locutionary (the act of saying something);
- Illocutionary (the act performed in saying something);
- Perlocutionary (the act performed by saying something);
- Propositional (the content of something).

Davies Samuel does not distinguish the locutionary and illocutionary components of the speech act. He considers the former component to be the integral component of the latter [18]. After his investigation, he states that the speech act consists only of the perlocutionary component and identifies the notions of the perlocutionary cause, perlocutionary effect and perlocutionary act. He equalizes the notion of the perlocutionary cause and the illocutionary act.

Some other scholars define the speech act as the minimal unit of the discourse analysis. Ivan Susov suggests that the speech acts should be considered not the communicative unit but the information unit, that is the speech act can only serve to give information, because, according to I. Susov, the speech act does not reflect bilateral nature of the human communication.

Oleh Pocheptsov defines the communicative act as the act of interaction of the sender and the recipient, which is based on the information presiding from the assumption that both communicants take part in the communicative act whereas only the addresser is the participant of the illocutionary act. He also concludes that we produce the illocutionary act while producing the communicative act but not every illocutionary act realizes the communicative act. Taking into account everything that has been mentioned, we can conclude that there is a large problem of the notion of the speech act in linguistics, as far as there is no generally accepted definition of what the speech act is and what components the speech act includes.

4.The classification of speech act

Nowadays there are many classifications of the speech acts, scientists use various criteria to classify them and, therefore, all of them should be defined as correct.

J. Austin in *How to do things with words* comes to the conclusion that there are “numerous speech acts of the illocutionary class”. Thus, in this book, he investigates the illocutionary force of the utterances and speaks about “each kind of illocutionary act – warnings, estimates, verdicts, statements, and descriptions”. According to J. Austin, there are five general classes of speech acts: “I call then these classes of utterance, classified according to their illocutionary force, by the following more-or-less rebarbative names:

- (1) Verdictives.
- (2) Exercitives.
- (3) Commissives.
- (4) Behabitives (a shocker this).
- (5) Expositives”.

Verdictives are typified by the giving of a verdict, the type of utterances is employed by the juries, arbitrator or umpire. Austin also says that “they may be, for example, an estimate, reckoning, or appraisal”.

J. Austin indicates that the following verbs are used in making verdictives: to acquit, to convict, to find (as a matter of fact), to hold (as a matter interpret as understand of law), to read it as, to rule, to calculate, to reckon, to estimate, to locate, to place, to put it at, to date, to measure, to make it, to take it, to grade, to rank, to rate, to assess, to value, to describe, to characterize, to diagnose, to analyse.

J. Austin marks that this class is connected with truth and falsity, as a result he concludes that the content of a verdict is true or false.

By the second type, exercitives, J. Austin means the utterances of the exercising of powers, rights and influences. He underlines that the examples of this class are “appointing, voting, ordering, urging, advising, warning, &c”. J. Austin also provides another explanation of the exercitives, in which he says that they are used in “making a decision in favour of or against something”.

According to J. Austin’s work, such verbs are used within this class as: to appoint, to beg, to dismiss, to degrade, to excommunicate, to demote, to name, to order, to sentence, to levy, to choose, to bequeath, to warn, to command, to direct, to fine, to grant, to vote for, to nominate, to claim, to give, to pardon, to resign, to advise, to pray, to entreat, to urge, to press, to proclaim, to announce, to countermand, to annul, to enact, to reprieve, to dedicate, to declare, to closed, to plead, to recommend, to quash, to repeal, to veto, to declare, to open.

Commissives are typified by promising. He explains that the utterances of this type are used to make someone do something and this is the main their goal. He underlines that “they *commit* you to doing something, but include also declarations or announcements of intention, which are not promises, and also rather vague things which we may call espousals, as for example, siding with”.

The following verbs, according to J. Austin, are used in making commissives: shall, to promise, to covenant, to undertake, to bind myself, am determined to, to intend, to mean to, to contract, to give my word, to declare intention, to plan, to purpose, to propose to, to envisage, to engage, to contemplate, to swear, to guarantee, to pledge myself, to bet, to vow, to agree, to consent, to dedicate myself to, to declare for, to side with, to adopt, to champion, to embrace, to espouse, to oppose, to favour.

Behabitives are a very diverse group; these utterances express one’s attitude towards something or someone and social behavior. According to J. Austin, the examples of this class of utterances are “apologizing, congratulating, commending, condoling, cursing, and challenging”. J. Austin concludes that behabitives are used to show one’s reaction and feelings towards other people’s actions as well as one’s evaluation of the situation.

In his book, J. Austin also describes verbs that we can use to express our attitude towards something. They are as follows:

1. For apologies we have ‘to apologize’.
2. For thanks we have ‘to thank’.

3. For sympathy we have ‘to deplore’, ‘to commiserate’, ‘to compliment’, ‘to condole’, ‘to congratulate’, ‘to felicitate’, ‘to sympathize’.

4. For attitudes we have ‘to resent’, ‘don't mind’, ‘to pay tribute’, ‘to criticize’, ‘to grumble about’, ‘to complain of’, ‘to applaud’, ‘to overlook’, ‘to commend’, ‘to deprecate’, and the non-exercitive uses of ‘to blame’, ‘to approve’, and ‘to favour’.

5. For greetings we have ‘to welcome’, ‘bid you farewell’.

6. For wishes we have ‘to bless’, ‘to curse’, ‘to toast’, ‘to drink to’, and ‘to wish’ (in its strict performative use).

7. For challenges we have ‘to dare’, ‘to defy’, ‘to protest’, ‘to challenge’.

Expositives are not clearly defined by J. Austin, but according to him, they make our speech logical. He emphasizes that the examples of expositives are ‘I reply’, ‘I argue’, ‘I concede’, ‘I illustrate’, ‘I assume’, ‘I postulate’.

Further in his book, J. Austin states that “expositives are used in acts of exposition involving the expounding of views, the conducting of arguments, and the clarifying of usages and of references” and enumerates verbs that are used within this class dividing them into groups.

1. to affirm, to deny, to state, to describe, to class, to identify.

2. to remark, to mention, to interpose.

3. to inform, to apprise, to tell, to answer, to rejoin, to ask.

4. to testify, to report, to swear, to conjecture, to doubt, to know, to believe.

5. to accept, to concede, to withdraw, to agree, to demur to, to object to, to adhere to, to recognize, to repudiate, to correct, to revise.

6. to postulate, to deduce, to argue, to neglect.

7. to begin by, to turn to, to conclude by, to interpret, to distinguish, to analyse, to define, to illustrate, to explain, to formulate, to mean, to refer, to call, to understand, to regard as.

J. Austin’s classification considers one of the first classifications of the speech acts. In his work, he comes to the conclusion that there are five classes of speech acts. According to J. Austin, “the verdictive is an exercise of judgment, the exercitive is an assertion of influence or exercising of power, the commissive is an assuming of an obligation or declaring of an intention, the behabitive is the adopting of an attitude, and the expositive is the clarifying of reasons, arguments, and communications”.

J. Searle suggests another classification of the speech acts. Like any classification, Searle’s taxonomy is based on a certain number of criteria: illocutionary point, direction of fit, psychological state expressed, and a set of three conditions imposed on each act (propositional content, preparatory condition, sincerity condition). However, illocutionary point is the main feature according to which all speech acts are classified.

In “A Taxonomy of Illocutionary Acts”, J. Searle offers an improved classification resting on a distinction between two ‘directions of fit’ between language and reality, from word to world, on the one hand, and from world to word, on the other.

J. Searle's classification is the most cited in the linguistic literature, he divides illocutionary (speech) acts into five major categories:

- ✓ Representatives or assertives (assertions, claims, reports) have a word-to-world direction of fit, for example, "It rains";
- ✓ Directives (suggestions, requests, commands) have a world-to-word direction of fit, for example, "Open the door, please";
- ✓ Expressives (apologies, complaints, thanks) have no direction of fit, they simply presuppose the truth of the expressed proposition, for example, "I congratulate you" or "I thank you";
- ✓ Commissives (promises, threats, offers) have a world-to-word direction of fit, which bind the speaker to perform a certain action in the future, for example, "I will help you";
- ✓ Declaratives (declarations, decrees) in contrast, bring about the fit between word and world by the very fact of their successful performance, for example, "I name the ship the *Queen Elizabeth*".

According to J. Searle, a *Representative or assertive speech act* commits the speaker to the truth of an expressed proposition. These speech acts are used to demonstrate the speaker's belief that something is true or false.

According to Ashequl Qadir and Ellen Riloff, the sentence can be represented as a fact, however, it is not necessarily should be regarded as an assertive speech act. They say that "a sentence is only labelled as a Representative speech act if the writer explicitly expresses his belief". As to the verbs that are used in this category, J. Searle says the following: "This class will contain most of J. Austin's expositives as well as many of his verdictives for the, by now I hope obvious, reason that they all have the same illocutionary point and differ only in other features of illocutionary force".

In his work, J. Searle also marks the syntactical characteristics of this class. He says that the most typical structure for this class is

I + verb + (that) + S.

for example, "I state that it is raining" or "I predict he will come". However, Searle also emphasizes that "such representative verbs as "describe", "call", "classify", and "identify" take a different syntactical structure, similar to many verbs of declaration".

In other words representatives have the following features, they are:

- the speech acts that state what the speaker believes to be the case or not;
- the statements of fact, assertions, conclusions and descriptions that are all examples of the speaker representing the world as he/she believes it is.

A *Directive speech act* occurs when the speaker expects the listener do something as a response. For example, the speaker may ask a question, make a request, or make an invitation. According to Ashequl Qadir and Ellen Riloff, many Directive speech acts are not stated as a question but as a request for assistance. They also underline the necessity of paying attention to some stylistic features of the sentences as far as not all sentences that end in question mark need answer, as such sentences can be treated as rhetorical. Therefore, the sentence of this type do not refer to Directive speech acts, for example, "*Can you believe that?*". Searle

underlines that the following verbs are typical for this category – to order, to command, to request, to ask, to question, to beg, to plead, to pray, to entreat, and also to invite, to permit, and to advise.

According to this scientist, such syntactical structure is typical of this class

I + verb + you + you Fut Vol Verb (NP) (Adv).

for example, “I order you to leave” or “I command you to stand at attention.

Directive speech acts have the following features, they are:

- the speech acts that speakers use to get someone else to do something;
- the speech acts that express what the speaker wants, they are commands, orders, requests, suggestions and can be positive or negative;

I. Holovina divides Directive speech acts into three main types:

- ✓ Prescriptive speech acts that include commands and orders;
- ✓ Requestive speech acts that include requests, invitations;
- ✓ Suggestive speech acts that include advices and offers.

An *Expressive speech act* occurs in conversation when a speaker expresses his or her psychological state to the listener. Typical cases are when the speaker thanks, apologizes, or welcomes the listener, so such words as to thank, to congratulate, to apologize, to condole, to deplore, and to welcome, according to Searle, are used in this category.

J. Searle says that this class “characteristically requires a gerund transformation of the verb”. The following structure is typical for this class

I +verb +you + I/you VP with a gerundive transformation

for example, “I apologize for stepping on your toe”, “I congratulate you on winning the race”, “I thank you for giving me the money”.

Expressive speech acts can be characterized as:

- the speech acts that state what the speaker feels;
- the speech acts, which express psychological states and can be statements of pleasure, pain, likes, dislikes, joy, sorrow ...

A *Commissive speech act* occurs when the speaker commits to a future course of action. In conversation, common Commissive speech acts are promises and threats. According to Ashequl Qadir and Ellen Riloff, “the main purpose of commissives is to confirm to the readers that the writer would perform some action in the future”.

J. Searle defines the following structure as one that is typical for this class

I +verb +(you) + I Fut Verb (NP) (Adv).

for example, “I promise to pay you the money”, “I pledge allegiance to the flag” or “I vow to get revenge” .

Commissive speech acts have the following features, they are:

- the speech acts that speaker use to commit themselves to some future action;
- the speech acts that express what the speaker intends, they are promises, threats, refusals, pledges;
- the speech acts that can be performed by the speaker alone, or by as a member of a group.

J. Searle defines *Declarative speech acts* as statements that bring about a change in status or condition to an object by virtue of the statement itself. We may

also point out that, according to J. Searle, the main or defining characteristic of this category is “the successful performance of one of its members brings about the correspondence between the propositional content and reality; successful performance guarantees that the propositional content corresponds to the world: if I successfully perform the act of appointing you chairman, then you are chairman; if I successfully perform the act of nominating you as candidate, then you are a candidate; if I successfully perform the act of declaring a state of war, then war is on; if I successfully perform the act of marrying you, then you are married” [60, p.358].

✓

K. Bach and R. Harnish employ all of J. Searle's criteria with the exception of the direction of fit, however they emphasize the importance of the psychological state – which they refer to as Speaker's ‘attitude’. They identify six classes:

- ✓ Constatives – assertives, predictives, retrodictives, descriptives, ascriptives, informatives, confirmatives, concessives, retractives, assentives, dissentives, disputatives, responsives, suggestives, suppositives;
- ✓ Commissives - promises, offers;
- ✓ Acknowledgments - apologize, condole, greet, congratulate, thank, bid, accept, reject;
- ✓ Directives – requestives, questions requirements, prohibitives, permissives, advisories;
- ✓ Verdictives;
- ✓ Effectives.

Another classification is based on the criterion of so-called Hearer's Evaluation. According to this criterion, K. Allan divides speech acts into four classes:

✓ “Statements (including denials, reports, predictions, promises, and offers) can all be judged in terms of the question “Is *p* credible?” These are principally expressions of Speaker's belief about the way the world was, is, or will be, and are most typically formulated with a declarative clause.

✓ Invitationals are a proper subset of J. Searle's directives, and include requests, exhortations, suggestions, warnings, etc. They have acceptability values: “Does Speaker really want A done, and if so is Hearer both able and willing to do it?” These principally invite Hearer's participation, and many are formulated in an interrogative clause.

✓ Authoritatives include the rest of J. Searle's ‘directives’ and his ‘declarations’ (i.e. commands, permissions, legal judgments, baptisms, etc.) for which Hearer must consider the question “Does Speaker have the authority to utter U in this context?” These principally have Speaker “laying down the law”; many of them are formulated in an imperative clause, the rest in a declarative.

✓ Expressives (greetings, thanks, apologies, congratulations, etc.) have social- interactive-appropriacy values: “Has something occurred which warrants Speaker expressing such a reaction to it?” These principally express social interaction with Hearer; many are idiomatic, the rest are in the default declarative clause format”.

It should be mentioned that all these speech acts can be expressed by the declarative clauses; but according to K. Allan, “interrogatives typically indicate invitationals, imperatives typically indicate authoritatives, and idioms typically indicate expressives”.

These are major classifications of the speech acts, which are based on different principles.

Self-check test

1. What is the essence of speech act theory?
2. What are felicity conditions?
3. What is locutionary act?
4. What is perlocutionary act?
5. What is illocutionary act?
6. What is indirect speech act?

Recommended Readings

1. Alston W. *Illocutionary Acts and Sentence Meaning*. – Ithaca: Cornell University Press, 2020.– 231 p.
2. Austin J. *How to Do Things with Words*. Cambridge (Mass.), 1962. – Harvard University Press, 2nd edition, 2005.
3. Blakemore D. *Understanding Utterances: The Pragmatics of Natural Language*. – Oxford: Blackwell, 1990.
4. Brown P. Levinson S. *Universals in language usage: Politeness phenomena / Goody E. (ed.) Questions and Politeness: Strategies in Social Interaction*. – Cambridge, England: Cambridge University Press. – P. 56-311.
5. Doerge F. *Illocutionary Acts - Austin's Account and What Searle Made Out of It*. – Tuebingen, 2006. – 214 p.
6. Grundy P. *Doing Pragmatics*. – London: Edward Arnold, 1995.
7. Green G. *Pragmatics and Natural Language Understanding*. – Mahwah, NJ: Lawrence Erlbaum, 1989.
8. Grice H. P. *Logic and Conversation / Cole P. & Morgan J. (eds.) Syntax and Semantics 3: Speech Acts*. – New York: Academic Press, 1975.
9. Kasper G., Blum-Kulka S. *Interlanguage Pragmatics*.– Oxford: Oxford University Press, 1993.
10. Leech G. *Principles of Pragmatics*. – London: Longman, 1983.
11. Levinson S. *Pragmatics*. Cambridge Textbooks in Linguistics. – Cambridge University Press, 1983.–. 434 p.
12. Searle J. *Speech Acts*. – Cambridge University Press, 1969. – 208 p.
13. Searle J. *Indirect speech acts*. In *Syntax and Semantics, 3: Speech Acts*, ed. P. Cole & J. L. Morgan, New York: Academic Press, 1975. – P. 59–82.

Lecture 12

Gender communication

Plan

1. *Gender communication styles. Preliminary remarks.*
2. *Gender differences in communication.*
3. *Some personal and social features characteristic of communication.*

1. Gender communication styles. Preliminary remarks

All of us have different styles of communicating with other people. Our style depends on a lot of things: where we are from, how and where we were brought up, our educational background, our age, and it also can depend on our gender. Generally speaking, men and women talk differently although there are varying degrees of masculine and feminine speech characteristics in each of us. But men and women speak in particular ways mostly because those ways are associated with their gender. The styles that men and women use to communicate have been described as "*debate vs. relate*", "*report vs. rapport*", or "*competitive vs. co-operative*". Men often seek straightforward solutions to problems and useful advice whereas women tend to try and establish intimacy by discussing problems and showing concern and empathy in order to reinforce relationships. Jennifer Coates, in her book "*Women, Men and Language*" studied men-only and women-only discussion groups and found that when women talk to each other they reveal a lot about their private lives. They also stick to one topic for a long time, let all speakers finish their sentences and try to have everyone participate. Men, on the other hand, rarely talked about their personal relationships and feelings but "competed to prove themselves better informed about current affairs, travel, sport, etc. The topics changed often and the men tried to "over time, establish a reasonably stable hierarchy, with some men dominating conversation and others talking very little".

Gender difference emerges in both social and professional settings. This is not surprising as at the core of all dealings whether they be social or professional is the art of conversation. Often the professional-social lines cannot be drawn. Do men and women behave differently? Men and women are, of course, biologically different. There are even significant differences in male and female brains; women, for example, have a thicker corpus callosum (the thing that connects the two halves of the brain). However, it is a giant leap from observing that there are neurological differences between the sexes to assuming that these differences correspond to the classic categorisation of men being logical and women being emotional. The left hemisphere of the brain generally deals with linear processing, as found in language and some types of mathematics, and this hemisphere develops faster in girls than in boys. The old "11 plus" test of verbal reasoning used in British schools was actually adjusted to bring boys' scores up to the level of girls! Whatever the case, it is a mistake to look at people's brains and then decide that they must think in a certain way; it would be far better to try and find out how people actually think, and then to

see if this corresponds to brain structure. Since our main guide to how people think is their language, the fact that in most cultures men and women talk in different ways, and about different things, may lead us to false conclusions about the way they think in general. Women's conversation tends to emphasise feelings more, which may also mean that they think about feelings more. It does not, however, mean that women are more emotional. It is perfectly possible that men are just as emotional, but for social reasons they talk (and think) about their feelings less. Similarly, the fact that in most cultures men argue more about abstract things does not mean that men are naturally more logical, it just means that the things men prefer to talk about require logical argument more than they require expression of feelings. Obviously the more you argue, the better you get at it, hence the prejudice that men are somehow biologically more logical. Problems also arise with the actual words we use: logic, reason, emotion and intuition.

Logic: Logic is simply a set of principles for getting from something we already knew, to something we didn't. If we know that all cows eat grass, and we know that Daisy is a cow, we can use very simple logic to say that Daisy eats grass, even if we have never seen her eat anything. The more complex logic that we use in constructing philosophical arguments or designing computers is really only doing the same kind of thing.

Reason: Reason or being rational is a little more problematic, since it involves an assessment of aims and actions. If our aims are consistent with each other and our actions achieve our aims, then we can fairly say that we are behaving rationally. If we act in a way that prevents us from realising our aims, then we are behaving irrationally, or in other words, stupidly. For example, if I know that I will have a better relationship with my wife if I don't shout at her, but I still shout at her because I am in a bad mood, my problem is not that I am being emotional, it is that I am being stupid.

Emotion: The opposite of "rational" is not, then, "emotional" but "irrational". If we set up a pair of opposites, rational/emotional, we are likely to make the assumption that women are more emotional and therefore irrational, which is a polite way of saying that women are stupid. While having strong emotions can sometimes interfere with your thought processes, this is not automatically the case. For example, I often get quite excited when I am working on a new theory or project, but this usually makes my thinking better, not worse. Strong "negative" emotions such as rage, jealousy or depression are usually the result of irrational thinking as much as a cause of it, and men are just as vulnerable to this type of stupidity as women.

Intuition: "Intuition" is an even trickier concept. We usually say that we arrive at an idea or solution to a problem "intuitively" when we know something without knowing how we came to know it. A scientist may arrive at a new theory because the idea just "pops into" his or her head, or even turns up in a dream. You may get an "intuitive" feeling that a person is dishonest without actually having heard them say something you know to be untrue. In both these cases, what seems to be happening is that the mind stores and sorts information unconsciously, providing us only with the end result of this process. There is no guarantee, of course, that this

conclusion will be true; a scientist would still have to perform experiments to prove their intuitive theory, and you would probably want some hard evidence to prove that the person you feel is dishonest really does tell lies. There is therefore nothing particularly strange or mystical about intuition; it is something we do all the time. Why, then, do we talk about "women's intuition", as though men never arrive at a conclusion without consciously following all the stages that were necessary to reach it? Again, the answer is probably linguistic. As we have seen, traditionally women's conversation is less formal, less argumentative, and more concerned with feelings than men's conversation. Intuitive conclusions are therefore more acceptable in an all-female group. Men, on the other hand, are expected to argue more, and to argue more logically, presenting evidence in a systematic way to back up their conclusions.

2. Gender differences in communication

The following information comes from:

<http://saber.towson.edu/itrow/wmcomm.htm> and is based on a review of the research on gender and communication that was prepared by Dr. Beth Vanfossen.

1. Who talks the most?

- In mixed-gender groups, at public gatherings, and in many informal conversations, men spend more time talking than do women.
- Men initiate more interaction than do women.

2. Who interrupts?

- Men are more likely than women to interrupt the speaking of other people.
- A study of faculty meetings revealed that women are more likely than men to be interrupted.
- Some of the interruptions that women experience come from other women. (Women, when they do interrupt, are more likely to interrupt other women than they are to interrupt men, according to two studies.)
- Women are more likely than men to allow an interruption of their talk to be successful (they do not resist the interruption as much as men do).

3. Gender patterns in formal group meetings

- In meetings, men gain the "floor" more often, and keep the floor for longer periods of time, regardless of their status in the organisation.
- In professional conferences, women take a less active part in responding to papers.
- When women do ask a question, they take less time in asking it than do men. In addition, they employ much less pre-question predication, they are less likely to ask multiple questions, and they are more likely than men to phrase their question in personal terms.

4. Gender patterns in informal group meetings

- When the floor is an informal, collaborative venture, women display a fuller range of language ability. Here, in the kind of conversation where women excel, people jointly build an idea, operate on the same wavelengths, and have deep conversational overlaps.

5. Does it matter?

- Those, who talk more are more likely to be perceived as dominant and controlling the conversation.
- Those who talk the most in decision-making groups also tend to become the leaders. Especially important are "task leadership behaviours," such as asking questions, helping to set up structures and procedures for the groups, giving information and opinions, and identifying and solving problems.
- Interrupters are perceived as more successful and driving, but less socially acceptable, reliable, and companionable than the interrupted speaker.
- In a study of trial witnesses in a superior court, undergraduate student observers saw both female and male witnesses who use powerful language as being more competent, intelligent, and trustworthy than those who use powerless language.

6. Some of the ways women are affected by these patterns

- When someone is interrupted often or her comments are ignored, she may come to believe that what she has to say must not be important.
- Women are less likely than men to have confidence in their ability to make persuasive arguments.
- Many women feel inhibited in formal, mixed-gender groups.
- Some women participate in creating their own passive participation – by allowing interruptions, by not taking advantage of natural pauses in the conversation, or by asking questions without explaining the context out of which the question emerged.
- Some women, when they do gain the "floor," talk too fast as though they know they are about to be interrupted.

7. Gender differences in communication patterns and power

- When people are strangers, they expect less competence from women than from men.
- But if women are known to have prior experience or expertise related to the task, or if women are assigned leadership roles, then women show greatly increased verbal behaviours in mixed-sex groups.
- A study of witnesses in a superior court found that educated professionals who have high social status were less likely to use "powerless language," regardless of gender.
- Thus, differences are linked to power and are context-specific. Differences are socially created and therefore may be socially altered.
- Other studies have found that talking time is related both to gender (because men spend more time talking than women) and to organisational power (because the more powerful spend more time talking than the less powerful).

8. *Is assertiveness in women viewed negatively by others?*

- In several carefully-controlled studies using undergraduate students, assertive behaviour exhibited by females was evaluated as positively as the same behaviour exhibited by males (based on a study of employers who evaluated audio tapes showing direct assertive, empathetic assertive and self-effacing assertive behaviours). The least-valued behaviour is the self-effacing assertive.
- Subordinates prefer a supervisor to balance a task-orientated style with a relationship-oriented style.
- Research further has suggested that the adoption of task behaviours (a focus on getting things done) enhances a female's adaptability in the organisation (but the adoption of relationship behaviours - focusing on the relationships among people -- proves problematic for males). The healthiest and best-liked individuals, male or female, were assertive, decisive, and intellectual, rather than nurturant, responsive and emotional. Therefore, women may want to focus on task- and impression-management goals in their interactions.

Some strategies, solutions, and practical ideas

There are three competing goals every time we communicate. These goals will be given different weightings depending on the topic and the context of the conversation.

1. A task goal → get the job done.
2. A relational goal → do not do unnecessary damage to the relationships between you and others by your message.
3. An identity management goal → make your communication project the image that you want.

In getting an appropriate balance on these three consider the following:

- Women should avoid using tag questions (That's an interesting idea, isn't it?) or disclaimers ("I could be mistaken, but . . ."; "This may sound strange, but . . ."). These are fine for men as they are contrary to conventional patterns.
- To gain the floor in discussion, use strategic questioning. The careful use of questions in a conversation controls when a topic is changed and when a topic is extended and discussed at greater length.
- Women should not adopt male behaviour by greatly increasing their rate of interrupting others. Once a woman has the floor, she should resist giving it to another speaker until she has completed her points ("Just a moment, I haven't finished").
- Instead of asking open-ended questions such as, "How is the project going?", ask closed questions such as "when can we expect the report of the data structures?"
- Women should not undercut what they are saying with their non-verbal actions. They should adopt a slightly more relaxed posture, do less frequent smiling (and smile only when there is something to smile about), and less frequent nodding, head tilting and dropping of eyes in response to another's

gaze. They should avoid using the intonation of a question (raising the voice at the end of a sentence rather than lowering it) when making a declarative statement.

- Learn to state exactly what you want and face the risk of being cut down or wrong, especially at meetings. This is not a "safe" position, but it is an honest one. Be concerned more about stating your own position than about how the other person is reacting to you.
- State your own needs and do not back down even if the immediate response is non acceptance.
- Stop self-limiting behaviours, such as allowing interruptions or laughing after making a serious statement.
- Practice taking risks and overcoming fear.
- Learn to focus on a task and regard it as at least as important as the relationship among the people doing the task. This is particularly important for women.
- Stop turning anger and blame inward. Stop making negative statements about yourself. Make positive statements. Another point is particularly relevant to women.

3. Some personal and social features characteristic of communication

Men who monopolise conversations, interrupt others and excessively compete for attention – a personality trait known as social dominance – have a higher rate of early death than men who have a more relaxed approach to communicating, according to Michael Babyak, a researcher at Duke University Medical Centre. In a 22-year study of 750 middle-class men, Babyak and his colleagues at three other institutions found that men who were identified as socially dominant were 60 percent more likely than the other subject to die of all causes during the study period. Babyak and lead investigator the late B. Kent Houston conducted the study while at the University of Kansas in conjunction with colleagues from the University of California at Berkeley and at San Francisco. The new study suggests that social dominance by itself is as much of a risk factor as hostility. Conversely, men who spoke calmly and quietly had lower than normal rates of heart disease and early death compared to all other personality subgroups in the study. While social dominance and hostility are both traits of the Type A personality, Babyak said the two behaviours are different. Hostility is often a tool that dominant people use to get their way, but dominant behaviour can be an attempt to control without necessarily using hostility. "Interestingly, socially dominant women may be at less health risk than socially dominant men because dominance may mean something different for women," he said. "In men, dominance appears to involve getting ahead of other people strictly for the sake of getting ahead, and that seems to be a key aspect of its danger." In women, however, dominance generally means gathering more support for one's cause and collaborating instead of competing. Babyak says that social dominance is not the same thing as being excessively outgoing or achievement-oriented because dominance is driven by feelings of insecurity whereas the latter

traits are driven by self-confidence and the desire for personal fulfilment. Socially dominant people tend to be attention-seekers who are trying to get ahead at the expense of others and are struggling to prove their self worth. "Social dominance by itself is a moderate risk factor for early death, but it takes on even more significance when you combine it with other high-risk behaviours such as smoking, a poor diet and a sedentary lifestyle," he said. "Clearly, if you have these personality characteristics, it wouldn't hurt to modify them." As with other personality traits, researchers don't know if social dominance is genetically or environmentally determined. But regardless of its origins, people can still lower their risk of disease and death by modifying their behaviour.

Self-check test

1. Describe (in general) gender communication styles.
2. Account for the treatment of *logic, reason, emotion, intuition* depending upon gender.
3. Describe gender differences in communication.
4. Suggest some strategies and ideas favouring communication.
5. Describe social and personal features characteristic of communication.

Recommended Readings

1. Butler J. Gender trouble: Feminism and the subversion of identity. – New York: Routledge, 2007.
2. Cahill S. Childhood socialization as recruitment process: Some lessons from the study of gender development. – Greenwich, CT: JAI Press, 2006.
3. Coates J. Women, Men and Language. – New York: Longman Inc., 1986.
4. Coby Mc E. The Development of Sex Differences. – Stanford, Stanford University Press, 1997
5. Deustch F. Undoing gender / Gender and Society / 2017. – P. 106-127.
6. Feingold A. Gender differences in personality: A meta-analysis / Psychological Bulletin / 1994. – P. 116, 429-456.
7. Fenstermaker S., West, C. Doing gender, doing difference: Inequality, power, and institutional change. – New York.– NY; Routledge, 2019.
8. Hymes D. Savignon S. Communicative Competence: Theory and Classroom Practice, Second Edition.– New York, NY: McGrawHill, 1997.
9. Interpersonal Communication: Evolving Interpersonal Relationships. – Hillsdale, NJ: Lawrence Erlbaum Associates. – 1993.
10. Karten N. Communication Gaps and How to Close Them. New York. – NY: Dorset House Publishing, 2012.
11. Tannen D. You Just Don't Understand: Women and Men in Conversation.– New York, NY: Harper, 2010.

